

Varispeed G7/F7 OPTION CARD
MECHATROLINK COMMUNICATIONS INTERFACE CARD
INSTRUCTIONS

MODEL: SI-T

Upon receipt of the product and prior to initial operation, read these instructions thoroughly and retain them for future reference.



Copyright © 2004 YASKAWA ELECTRIC CORPORATION

All rights reserved. No part of this publication may be reproduced, stored in a retrieval system, or transmitted, in any form, or by any means, mechanical, electronic, photocopying, recording, or otherwise, without the prior written permission of Yaskawa. No patent liability is assumed with respect to the use of the information contained herein. Moreover, because Yaskawa is constantly striving to improve its high-quality products, the information contained in this manual is subject to change without notice. Every precaution has been taken in the preparation of this manual. Nevertheless, Yaskawa assumes no responsibility for errors or omissions. Neither is any liability assumed for damages resulting from the use of the information contained in this publication.

Introduction

Thank you for purchasing a Current Vector Control General-purpose Varispeed G7/F7 Inverter and a SI-T MECHATROLINK-I/MECHATROLINK-II Communications Interface Card (called "SI-T Card" below).

This manual describes the operation and specifications of the SI-T Card, which connects to the MECHATROLINK-I/MECHATROLINK-II high-speed field network for exchanging data. Be sure that you have read and understood this manual before attempting to operate the SI-T Card.

For details on operating the Inverter itself, refer to the Varispeed G7/F7 Series Instruction Manual (TOE-S616-60.1, TOE-S616-55.1).

Yaskawa Electric, Inc.

General Precautions

- The diagrams in this manual may be indicated without covers or safety shields in order to show details. Be sure to restore covers or shields before operating the Inverter, and operate the Inverter according to the instructions provided in this manual.
- The products and specifications described in this manual or the contents and presentation of the manual may be changed without notice to improve the product and/or the manual.
- When ordering a new copy of the manual due to damage or loss, contact your Yaskawa representative or the nearest Yaskawa sales office and provide the manual number shown on the front cover.
- Any modifications to the product by the customer invalidate the warranty, and Yaskawa accepts no responsibility for the results of any modifications

Safety Precautions

Carefully read this manual and all other documentation provided with the product before attempting to install, operate, inspect, or perform maintenance on the product. Within this manual, safety-related precautions are classified a “warnings” and “cautions.”



Indicates precautions that, if not heeded, could possibly result in loss of life or serious injury.



Indicates precautions that, if not heeded, could result in relatively less serious or minor injury, or damage to the equipment.

Failure to heed even a precaution classified as a caution can result in serious consequences depending on the situation. All precautions contain important information, so make sure that they are followed carefully.



Indicates important information that the user should make careful note of, even though it is not classified as a caution.

■ Confirmations upon Delivery

CAUTION

- Never use an Option Card that is damaged or missing components.
Doing so can result in injury.

■ Installation and Wiring

WARNING

- Never touch the inside of the Inverter with your hands.
Doing so can result in electric shock.
- Before installing or removing the Option Card, or performing wiring operations, always turn OFF the power to the Inverter and wait until the specified period of time has elapsed after all the Inverter indicators have turned OFF. (The time is shown on the Inverter's front cover.)
Failure to do so can result in electric shock.
- Do not allow cables to be damaged, subjected to stress, placed under heavy objects, or pinched.
Doing so can result in electric shock, faulty operation, or damage to the equipment.

CAUTION

- Never touch the Option Card terminals directly with your hands.
Doing so can result in damage from static electricity.
- Insert the connectors securely.
Failure to do so can result in damage or faulty operation of devices.

■ Settings

CAUTION

- Do not carelessly change the Inverter's settings.
Doing so can result in damage or faulty operation of devices.

Warranty Information

■ Free Warranty Period and Scope

■ Warranty Period

This product is warranted for twelve months after being delivered to Yaskawa's customer or if applicable eighteen months from the date of shipment from Yaskawa's factory, whichever comes first.

■ Scope of Warranty

Inspections

Periodic inspections must be conducted by the customer. However, upon request, Yaskawa or one of Yaskawa's Service Centers can inspect the product for a fee. In this case, if after conferring with the customer, a Yaskawa product is found to be defective due to Yaskawa workmanship or materials and the defect occurs during the warranty period, then this fee will be waived and the problem remedied free of charge.

Repairs

If a Yaskawa product is found to be defective due to Yaskawa workmanship or materials and the defect occurs during the warranty period, Yaskawa will provide a replacement, repair the defective product, and provide shipping to and from the site free of charge.

However, if the Yaskawa Authorized Service Center determines that the problem with a Yaskawa product is not due to defects in Yaskawa's workmanship or materials, then the customer will be responsible for the cost of any necessary repairs. Some problems that are outside the scope of this warranty are:

- Problems due to improper maintenance or handling, carelessness, or other reasons where the customer is determined to be responsible.
- Problems due to additions or modifications made to a Yaskawa product without Yaskawa's understanding.
- Problems due to the use of a Yaskawa product under conditions that do not meet the recommended specifications.
- Problems caused by natural disaster or fire.
- Or other problems not due to defects in Yaskawa workmanship or materials.

Warranty service is only applicable within Japan.

However, after-sales service is available for customers outside of Japan for a reasonable fee. Contact your local Yaskawa representative for more information.

■ Exceptions

Any inconvenience to the customer or damage to non-Yaskawa products due to Yaskawa's defective products whether within or outside the warranty period are NOT covered by this warranty.

Restrictions

- The SI-T Card was not designed or manufactured for use in devices or systems that may directly affect or threaten human lives or health.
- Customers who intend to use the product described in this manual for devices or systems relating to transportation, health care, space aviation, atomic or electric power, or underwater use must contact their Yaskawa representatives or the nearest Yaskawa sales office beforehand.
- This product has been manufactured under strict quality-control guidelines. However, if this product is to be installed in any location where failure of this product could involve or result in a life-and-death situation or loss of human life or in a facility where failure may cause a serious accident or physical injury, safety devices must be installed to minimize the likelihood of any accident.

CONTENTS

Introduction	3
Safety Precautions	4
Warranty Information	6
Restrictions	7
1 Overview	9
2 Checking the Product	9
2.1 Type and Code No.	9
2.2 Parts List	10
3 Component Names and Settings	10
3.1 Component Names	10
3.2 Communications Connectors	11
3.3 LED Indicators	11
3.4 Switch Setting	12
4 Installation and Wiring	14
4.1 Installing the SI-T Card	14
4.2 MECHATROLINK Communications Cables	16
5 Inverter Setting	17
6 Communications Specifications	18
Revision History	

1 Overview

The SI-T Card is an interface card that connects to the MECHATROLINK-I or MECHATROLINK-II high-speed field network for communicating with the host controller.

By installing the SI-T Card to a Varispeed G7/F7-series Inverter, various applications are enabled; monitoring of the run/stop status and the operating conditions as well as the changing and the referencing of the settings for the Inverter constants from the host controller.

The SI-T Card can be installed in the following Inverters.

- Varispeed G7-series Inverter, software No. 656X.
- Varispeed F7-series Inverter (SPEC:E or later), software No.103X.

Note: "X" indicates the design revision order.

IMPORTANT

Varispeed G7/F7 Inverter with an SI-T Card does not conform to CE Marking, although the Varispeed G7/F7 Inverter itself conforms to CE Marking.

2 Checking the Product

Check the following items as soon as the product is delivered.

Item	Method
Is there any discrepancy between the shipment and what was ordered?	Check the type and code No. printed on the center of the Card. (Refer to 2.1 and 3.1.)
Has the product been damaged in any way?	Inspect the entire exterior of the Card for any damage that may have occurred during shipping.
Are the contents of the package correct?	Check the contents shown in the following table. (Refer to 2.2.)

Contact your Yaskawa representative immediately if any failure should be found concerning the above items.

2.1 Type and Code No.

The following shows the type and code No. on the center of the SI-T Card.

Type: SI-T

Code No.: ETC61862X-S016X

Note: "X" indicates the design revision order.

2.2 Parts List

The SI-T Card contains the following parts.

Parts Name	Qty
SI-T Communications Interface Card	1
Grounding cable (Already mounted on the SI-T Card)	1
Instruction Manual (This manual)	1

3 Component Names and Settings

3.1 Component Names

The following diagram shows the SI-T Card external appearance and component names.

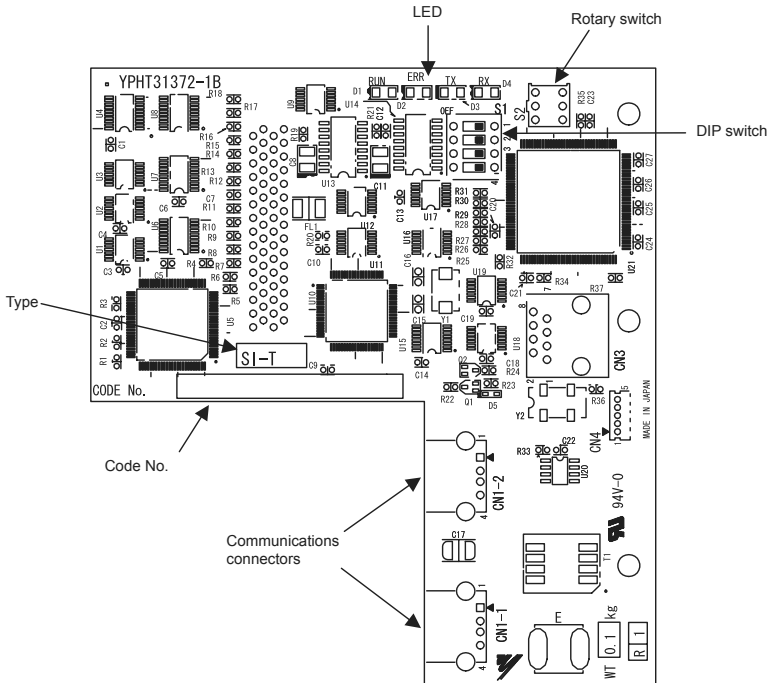

3.2 Communications Connectors

The communications connectors (CN1-1 and CN1-2) connect the SI-T Card to the communications lines of the MECHATROLINK-I or MECHATROLINK-II. The following table shows the pin numbers and their functions.

Connector	Pin No.	Signal Name	I/O	Function
CN1-1	1	(NC)	–	Not used.
	2	SRD–	I/O	Send/receive data (-)
	3	SRD+	I/O	Send/receive data (+)
	4	(NC)	–	Not used.
	Shell	Shield	–	Not used.
CN1-2	1	(NC)	–	Not used.
	2	SRD–	I/O	Send/receive data (-)
	3	SRD+	I/O	Send/receive data (+)
	4	(NC)	–	Not used.
	Shell	Shield	–	Not used.

3.3 LED Indicators

The LED indicators indicate the status of the communications of the MECHATROLINK-I or MECHATROLINK-II and the SI-T Card.

However, these indicators are for maintenance checks at Yaskawa. Use the Digital Operator to check the status.

Name	Display		Explanation
	Color	Status	
RUN	Green	Lit	Normal operation
	–	Not lit	Communications CPU stopped, resetting hardware, RAM check error, DPRAM check error, station address setting error, or Inverter model code error
ERR	Red	Lit	Watchdog timeout error, communications error, diagnosis error, or resetting hardware
	Red	Blinking	ROM check error (once)*, RAM check error (twice)*, DPRAM check error (3 times)*, communications ASIC self-diagnosis error (4 times)*, ASIC RAM check error (5 times)*, station address setting error (6 times)*, Inverter model code error (7 times)* *: Indicates the number of blinking.
	–	Not lit	No communications error or self-diagnosis error
TX	Green	Lit	Sending data
	–	Not lit	Sending of data stopped, hardware reset
RX	Green	Lit	Searching for receiving carrier
	–	Not lit	No receiving carrier found, resetting hardware

3.4 Switch Setting

■ DIP Switch

The following table shows the SI-T Card DIP switch settings.

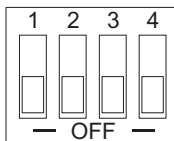

Name	Label	Status	Function	Factory Setting
Baud rate	S1-1	OFF	4 Mbps (MECHATROLINK-I)* ¹	ON
		ON	10 Mbps (MECHATROLINK-II)	
Data length	S1-2	OFF	17-byte data transmission (MECHATROLINK-I/ MECHATROLINK-II)	ON
		ON	32-byte data transmission (MECHATROLINK-II)* ¹	
Station address	S1-3	OFF	Set the 10's digit of the station number to 2. Invalid if the maximum number of units including the S2 of the rotary switch is 20.	OFF
		ON	Set the 10's digit of the station number to 3. Invalid if the maximum number of units including the S2 of the rotary switch is 3F.	
Maintenance	S1-4	OFF	Normally OFF* ²	OFF
		ON	Not used.	

* 1. Invalid if S1-1 is OFF (4 Mbps) and S1-2 is ON (32-byte data transmission).

* 2. For maintenance. Always leave this switch OFF.

■ Rotary Switch

The following table shows the SI-T Card rotary switch settings.

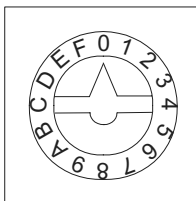

Label	Status	Function	Factory Setting
S2	0 to F	Set the 1's digit of the station number :X0H-XFH. Invalid if the maximum number of units including the S1-3 is 20 or 3F.	1

Note: Although the range that can be set by S1-3 and S2 is from 20 to 3F, 20 and 3F are invalid (the ERR LED indicator blinks six times).

Therefore, the actual setting range is from 21 to 3E.

Refer to the following section *Station-number Setting* for details.

■ Station-number Setting

A station number is set by both the S1-3 DIP switch and the S2 rotary switch. Station numbers from 21 to 3E are valid. Although 20 or 3F can be set as a station number, do not use these settings because they will be faulty.

S1-3: Set the 10's digit of the station number.

OFF = 2 (2X)

ON = 3 (3X)

S2: Set the 1's digit of the station number.

0 = 0 (X0)

1 = 1 (X1)

· ·

· ·

F = F (XF)

Switch Setting and Station Number

S1-3	S2	Station Number	S1-3	S2	Station Number
OFF	0	Fault	ON	0	30
OFF	1	21	ON	1	31
OFF	2	22	ON	2	32
OFF	3	23	ON	3	33
OFF	4	24	ON	4	34
OFF	5	25	ON	5	35
OFF	6	26	ON	6	36
OFF	7	27	ON	7	37
OFF	8	28	ON	8	38
OFF	9	29	ON	9	39
OFF	A	2A	ON	A	3A
OFF	B	2B	ON	B	3B
OFF	C	2C	ON	C	3C
OFF	D	2D	ON	D	3D
OFF	E	2E	ON	E	3E
OFF	F	2F	ON	F	Fault

4 Installation and Wiring

WARNING

- Before installing or removing the Option Card, or performing wiring operations, always turn OFF the power to the Inverter and wait until the specified period of time has elapsed after all the Inverter indicators have turned OFF. (The time is shown on the Inverter's front cover.)

Failure to do so can result in electric shock.

IMPORTANT

Route the MECHATROLINK communications cables separately from the main circuit wiring and other power lines.

4.1 Installing the SI-T Card

Use the following procedure to mount the SI-T Card after removing the Inverter's Digital Operator and front cover.

1. Turn OFF the Inverter's main-circuit power supply.
2. Confirm that all the indicators on the Inverter have turned OFF, wait until the specified period of time has elapsed (the time is shown on the Inverter's front cover), and then remove the Digital Operator and the front cover. Verify that the CHARGE lamp is unlit.
3. Remove the Option Clip (the clip to secure option C or D) on the Inverter. The Clip can be easily pulled out by pinching its projections.
4. Install the SI-T Card on the option C connector 2CN (60 pins) on the Inverter control board. Secure the Card by inserting the spacers on the control board into the spacer mounting holes (three holes) of the Card until hearing a "click." (Refer to A in Fig.1.)

Note: The SI-T Card (option C) and option D cannot be used at the same time.

5. Insert the Option Clip to its original position.
6. Connect the Card grounding cable to the control circuit terminal E (G) on the Inverter control board.
7. After the Card is installed, connect the communications cables and set the DIP switches. (Refer to 3.4 and 4.2.)
8. Remount the Digital Operator and the front cover.

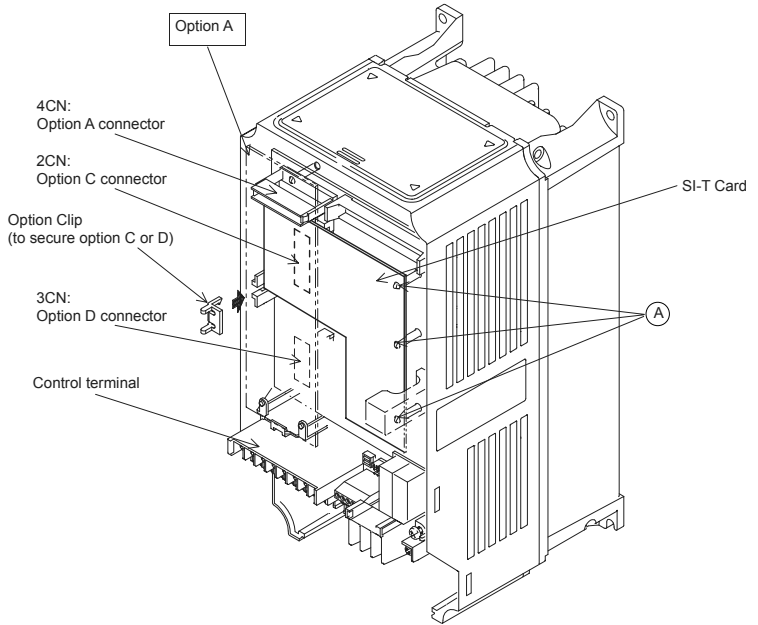

Fig. 1 Installation of the SI-T Card

4.2 MECHATROLINK Communications Cables

■ Wiring

Wire the MECHATROLINK communications cables to the communications connector (CN2).

IMPORTANT

- For communications cables, use special shielded twisted-pair cables for MECHATROLINK communications.
Recommended cable: JEPMC-W603-□□ *
* □□ is the length (m).
With USB connector with core
- Install MECHATROLINK communications cables apart from main-circuit wiring and other electrical and power lines.
- Connect the terminator (model No.: JEPMC-W6022) on the end of the communication lines.
- Maximum transmission distance is 50 m.
- Maximum wiring distance between stations is 0.5 m.

■ Communications Wiring Example

The following diagram is an example of communications wiring around the Inverters.

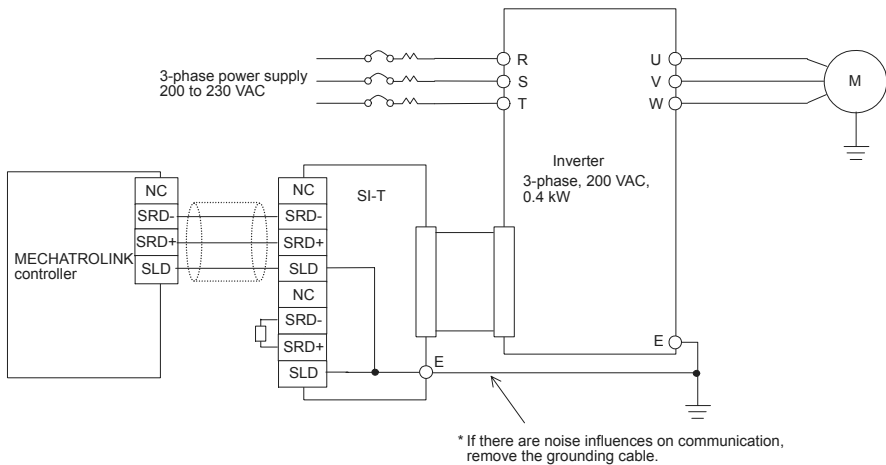

Fig. 2 Connection Diagram with Varispeed G7/F7 (3-phase, 200 VAC, 0.4 kW)

5 Inverter Setting

Perform the following constant setting, whenever necessary, before starting communications between the Inverter and the MECHATROLINK-I/MECHATROLINK-II master.

To run or stop through the MECHATROLINK communications, set 3 to B1-02. To set frequency, set 3 to B1-01.

For details, refer to the Varispeed G7/F7 Series Instruction Manual (TOE-S616-60.1, TOE-S616-55.1).

Constant No.	Name	Description	Factory Setting
B1-02	Run command selection	0: Digital Operator 1: Control circuit terminal 2: MEMOBUS communications 3: Communications Option Card (Optional)	1
B1-01	Frequency reference selection	0: Digital Operator 1: Voltage reference 2: MEMOBUS communications 3: Communications Option Card (Optional) 4: Pulse train reference	1

6 Communications Specifications

Item	Contents
Baud rate	4 Mbps or 10 Mbps* ¹
Access mode	Start-stop synchronization, master/slave method
Transmission cycle	500 μ s to 8 ms* ²
Max. transmission distance	50 m* ⁵
Data length	17-byte data transmission or 32-byte data transmission* ³
Max. number of slaves	30* ⁴ * ⁵

- * 1. The baud rate is 4 Mbps for MECHATROLINK-I, and 10 Mbps for MECHATROLINK-II.
- * 2. For MECHATROLINK-I, a cycle is 2 ms. For MECHATROLINK-II, a cycle is 1 ms to 8 ms for a 32-byte data transmission, and 500 μ s to 8 ms for a 17-byte data transmission.
- * 3. For MECHATROLINK-I, only a 17-byte data transmission can be selected.
- * 4. The maximum number of connectable stations changes depending on the types and settings of the host controller, baud rate, or communications cycle. For details, refer to the manuals of your controller.
 Communications cycle: Integral multiple of transmission cycles (depending on the host controller settings).
 Example: If the host controller is an MP2300
 - For MECHATROLINK-II (32-byte transmission, 2-ms communications cycle):
21 stations max. (21 slaves can be set, but then the maximum number of connectable Inverters will be 16.)
 - For MECHATROLINK-II (32-byte transmission, 1-ms communications cycle):
9 stations max.
 - For MECHATROLINK-II (17-byte transmission, 1-ms communications cycle):
15 stations max.
 - For MECHATROLINK-I: 14 stations max.
- * 5. At the maximum transmission distance of 50 m, the maximum number of slaves is 15.

Revision History

The revision dates and numbers of the revised manuals are given on the bottom of the back cover.

MANUAL NO. TOBP C730600 08A

Printed in Japan September 2004 04-9 \diamond
└─ Date of printing └─ Date of original publication └─ Revision number

Date of Printing	Rev. No.	Section	Revised Content
September 2004	—		First edition
December 2004	$\diamond 1$	3	Addition: Station-number Setting
March 2006	$\diamond 2$	Back cover	Revision: Address
April 2007	$\diamond 3$	Back cover	Revision: Address

Varispeed G7/F7 OPTION CARD MECHATROLINK COMMUNICATIONS INTERFACE CARD INSTRUCTIONS

IRUMA BUSINESS CENTER (SOLUTION CENTER)

480, Kamifujisawa, Iruma, Saitama 358-8555, Japan
Phone 81-4-2962-5696 Fax 81-4-2962-6138

YASKAWA ELECTRIC AMERICA, INC.

2121 Norman Drive South, Waukegan, IL 60085, U.S.A.
Phone 1-847-887-7000 Fax 1-847-887-7370

YASKAWA ELÉTRICO DO BRASIL COMÉRCIO LTD.A.

Avenida Fagundes Filho, 620 Bairro Saude-Sao Paulo-SP, Brazil CEP: 04304-000
Phone 55-11-5071-2552 Fax 55-11-5581-8795

YASKAWA ELECTRIC EUROPE GmbH

Am Kronberger Hang 2, 65824 Schwalbach, Germany
Phone 49-6196-569-300 Fax 49-6196-569-312

YASKAWA ELECTRIC UK LTD.

1 Hunt Hill Orchardton Woods Cumbernauld, G68 9LF, United Kingdom
Phone 44-1236-735000 Fax 44-1236-458182

YASKAWA ELECTRIC KOREA CORPORATION

7F, Doore Bldg. 24, Yeoido-dong, Youngdungpo-Ku, Seoul 150-877, Korea
Phone 82-2-784-7844 Fax 82-2-784-8495

YASKAWA ELECTRIC (SINGAPORE) PTE. LTD.

151 Lorong Chuan, #04-01, New Tech Park 556741, Singapore
Phone 65-6282-3003 Fax 65-6289-3003

YASKAWA ELECTRIC (SHANGHAI) CO., LTD.

No.18 Xizang Zhong Road, Room 1702-1707, Harbour Ring Plaza Shanghai 200001, China
Phone 86-21-5385-2200 Fax 86-21-5385-3299

YASKAWA ELECTRIC (SHANGHAI) CO., LTD. BEIJING OFFICE

Room 1011A, Tower W3 Oriental Plaza, No.1 East Chang An Ave.,
Dong Cheng District, Beijing 100738, China
Phone 86-10-8518-4086 Fax 86-10-8518-4082

YASKAWA ELECTRIC TAIWAN CORPORATION

9F, 16, Nanking E. Rd., Sec. 3, Taipei, Taiwan
Phone 886-2-2502-5003 Fax 886-2-2505-1280



YASKAWA ELECTRIC CORPORATION

YASKAWA

In the event that the end user of this product is to be the military and said product is to be employed in any weapons systems or the manufacture thereof, the export will fall under the relevant regulations as stipulated in the Foreign Exchange and Foreign Trade Regulations. Therefore, be sure to follow all procedures and submit all relevant documentation according to any and all rules, regulations and laws that may apply.

Specifications are subject to change without notice for ongoing product modifications and improvements.

© 2004-2007 YASKAWA ELECTRIC CORPORATION. All rights reserved.

MANUAL NO. TOBP C730600 08B

Printed in Japan April 2007 04-9 -0
05-7②