

VS mini V7 OPTION UNIT
MECHATROLINK COMMUNICATIONS INTERFACE UNIT
USER'S MANUAL

Model: SI-T/V7

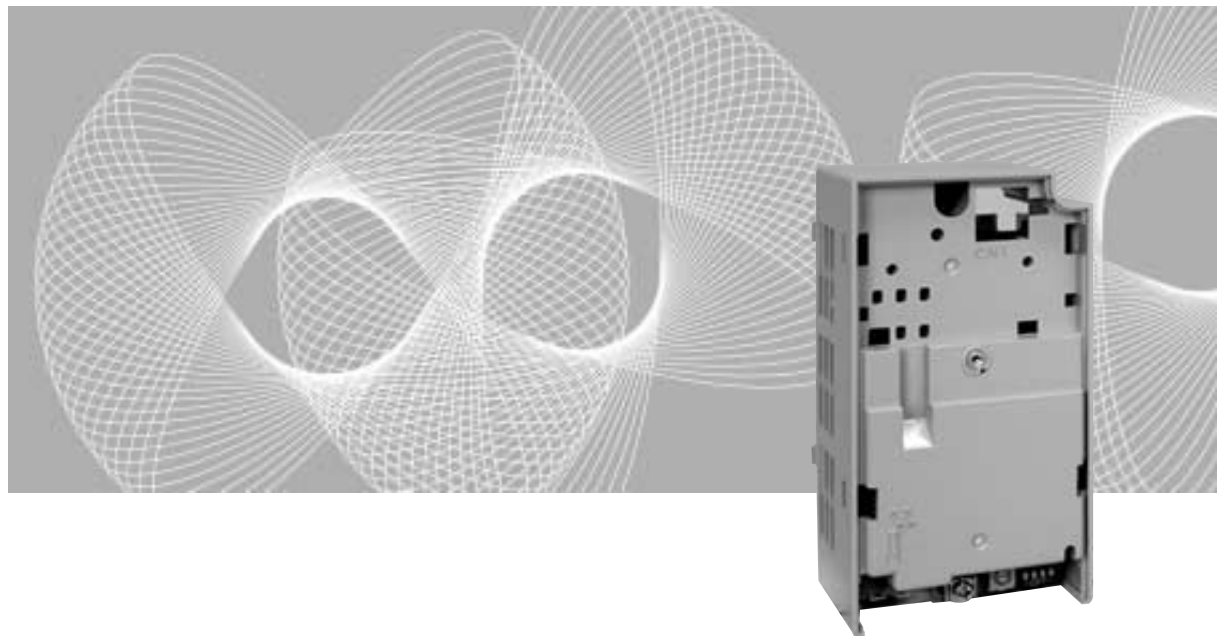

YASKAWA

MANUAL NO. SIBP C730600 03A

Copyright © 2005 YASKAWA ELECTRIC CORPORATION

All rights reserved. No part of this publication may be reproduced, stored in a retrieval system, or transmitted, in any form, or by any means, mechanical, electronic, photocopying, recording, or otherwise, without the prior written permission of Yaskawa. No patent liability is assumed with respect to the use of the information contained herein. Moreover, because Yaskawa is constantly striving to improve its high-quality products, the information contained in this manual is subject to change without notice. Every precaution has been taken in the preparation of this manual. Nevertheless, Yaskawa assumes no responsibility for errors or omissions. Neither is any liability assumed for damages resulting from the use of the information contained in this publication.

Introduction

Thank you for purchasing a Vector-control General-purpose VS-606V7 Inverter and a SI-T/V7 MECHATROLINK-I/MECHATROLINK-II Communications Interface Unit (called “SI-T/V7 Unit”).

This manual describes the operation and specifications of the SI-T/V7 Unit, which connects to the MECHATROLINK-I/MECHATROLINK-II open field network for exchanging data. Be sure that you have read and understood this manual before attempting to operate the SI-T/V7 Unit.

For details on operating the Inverter itself, refer to the VS-606V7 Series Instruction Manual (TOE-S606-11).

Yaskawa Electric Corporation

General Precautions

- The diagrams in this manual may be indicated without covers or safety shields in order to show details. Be sure to restore covers or shields before operating the Inverter, and operate the Inverter according to the instructions provided in this manual.
- The products and specifications described in this manual or the contents and presentation of the manual may be changed without notice to improve the product and/or the manual.
- When ordering a new copy of the manual due to damage or loss, contact your Yaskawa representative or the nearest Yaskawa sales office and provide the manual number shown on the front cover.
- Any modifications to the product by the customer invalidate the warranty, and Yaskawa accepts no responsibility for the results of any modifications

Safety Precautions

Carefully read this manual and all other documentation provided with the product before attempting to install, operate, inspect, or perform maintenance on the product. Within this manual, safety-related precautions are classified a “warnings” and “cautions.”



Indicates precautions that, if not heeded, could possibly result in loss of life or serious injury.



Indicates precautions that, if not heeded, could result in relatively less serious or minor injury, or damage to the equipment.

Failure to heed even a precaution classified as a caution can result in serious consequences depending on the situation. All precautions contain important information, so make sure that they are followed carefully.

IMPORTANT

Indicates important information that the user should make careful note of, even though it is not classified as a caution.

■ Confirmations upon Delivery

CAUTION

- Never use an Option Unit that is damaged or missing components.
Doing so can result in injury.

■ Installation and Wiring

WARNING

- Never touch the inside of the Inverter with your hands.
Doing so can result in electric shock.
- Before installing or removing the Option Unit, or performing wiring operations, always turn OFF the power to the Inverter and wait until the specified period of time has elapsed after all the Inverter indicators have turned OFF. (The time is shown on the Inverter's front cover.)
Failure to do so can result in electric shock.
- Do not allow cables to be damaged, subjected to stress, placed under heavy objects, or pinched.
Doing so can result in electric shock, faulty operation, or damage to the equipment.

CAUTION

- Never touch the Option Unit terminals directly with your hands.
Doing so can result in damage from static electricity.
- Insert the connectors securely.
Failure to do so can result in damage or faulty operation of devices.

■ Settings

CAUTION

- Do not carelessly change the Inverter's settings.
Doing so can result in damage or faulty operation of devices.

Warranty Information

■ Free Warranty Period and Scope

■ Warranty Period

This product is warranted for twelve months after being delivered to Yaskawa's customer or if applicable eighteen months from the date of shipment from Yaskawa's factory, whichever comes first.

■ Scope of Warranty

Inspections

Periodic inspections must be conducted by the customer. However, upon request, Yaskawa or one of Yaskawa's Service Centers can inspect the product for a fee. In this case, if after conferring with the customer, a Yaskawa product is found to be defective due to Yaskawa workmanship or materials and the defect occurs during the warranty period, then this fee will be waived and the problem remedied free of charge.

Repairs

If a Yaskawa product is found to be defective due to Yaskawa workmanship or materials and the defect occurs during the warranty period, Yaskawa will provide a replacement, repair the defective product, and provide shipping to and from the site free of charge.

However, if the Yaskawa Authorized Service Center determines that the problem with a Yaskawa product is not due to defects in Yaskawa's workmanship or materials, then the customer will be responsible for the cost of any necessary repairs. Some problems that are outside the scope of this warranty are:

- Problems due to improper maintenance or handling, carelessness, or other reasons where the customer is determined to be responsible.
- Problems due to additions or modifications made to a Yaskawa product without Yaskawa's understanding.
- Problems due to the use of a Yaskawa product under conditions that do not meet the recommended specifications.
- Problems caused by natural disaster or fire.
- Or other problems not due to defects in Yaskawa workmanship or materials.

Warranty service is only applicable within Japan.

However, after-sales service is available for customers outside of Japan for a reasonable fee. Contact your local Yaskawa representative for more information.

■ Exceptions

Any inconvenience to the customer or damage to non-Yaskawa products due to Yaskawa's defective products whether within or outside the warranty period are NOT covered by this warranty.

Restrictions

- The SI-T Card was not designed or manufactured for use in devices or systems that may directly affect or threaten human lives or health.
- Customers who intend to use the product described in this manual for devices or systems relating to transportation, health care, space aviation, atomic or electric power, or underwater use must contact their Yaskawa representatives or the nearest Yaskawa sales office beforehand.
- This product has been manufactured under strict quality-control guidelines. However, if this product is to be installed in any location where failure of this product could involve or result in a life-and-death situation or loss of human life or in a facility where failure may cause a serious accident or physical injury, safety devices must be installed to minimize the likelihood of any accident.

CONTENTS

1 Overview	9
2 Checking the Product	10
2.1 Nameplate	10
2.2 Parts List	10
3 Component Names and Settings	11
3.1 Component Names	11
3.2 Communications Connectors (CN2)	11
3.3 LED Indicators	12
3.4 Switch Setting	13
4 Installation and Wiring	15
4.1 Installing the SI-T/V7 Unit	15
4.2 MECHATROLINK Communications Cables	17
5 Transmission Interface	18
5.1 MECHATROLINK-II Cyclic Transmissions	18
5.2 Basic Format of Data Transfer	19
5.3 Communications Phases	20
5.4 Application Layer Specifications	21
6 Initial Setup	22
7 MECHATROLINK-II Commands	23
7.1 Main Commands	23
7.2 Sub-commands	37
7.3 Status Details	42
8 Protective Operations	44
8.1 Fault Detection Processing	44
8.2 Alarm Processing	45
9 Specifications	49

1 Overview

The SI-T/V7 Interface Unit is an interface unit that connects to the high-speed MECHATROLINK-I or MECHATROLINK-II high-speed field network for communicating with the host controller.

By installing the SI-T/V7 Unit to a VS-606V7-series Inverter, various applications are enabled; monitoring of the run/stop status and the operating conditions as well as the changing and the referencing of the settings for the Inverter constants from the host controller.

The SI-T/V7 Unit can be installed in the following Inverters.

- VS-606V7-series Inverters, software version No. 565X.
- VS-606V7-series Inverters, software version No. 573X.

Note: 1. "X" indicates the design revision order.
2. Version No. 573X will replace No. 5650.
3. The Inverter constant cannot be copied from version No.5650 to No.573X with the Inverter constant copy function if using a Digital Operator.

IMPORTANT

VS-606V7 Inverter with an SI-T/V7 Unit does not conform to CE Marking, although the VS-606V7 Inverter itself conforms to CE Marking.

2 Checking the Product

Check the following items as soon as the product is delivered.

Item	Method
Is there any discrepancy between the shipment and what was ordered?	Check the information printed on the Unit. Refer to 2.1 <i>Nameplate</i> .
Has the product been damaged in any way?	Inspect the entire exterior of the Unit for any damage that may have occurred during shipping.
Are the contents of the package correct?	Check the contents. Refer to 2.2 <i>Parts List</i> .

Contact your Yaskawa representative immediately if any failure should be found concerning the above items.

2.1 Nameplate

The following diagram shows the nameplate on the side of the SI-T/V7 Unit.

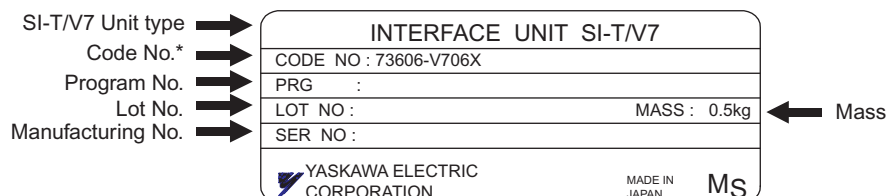

* "X" indicates the design revision order.

2.2 Parts List

The SI-T/V7 Unit contains the following parts.

Parts Name	Qty
SI-T/V7 Communications Interface Unit	1
Mounting fixture	1
M3 × 8 SW screw	1
Grounding cable (small)	1
Grounding cable (medium)	1
Grounding cable (large)	1

3 Component Names and Settings

3.1 Component Names

The following diagram shows the SI-T/V7 Unit external appearance and component names.

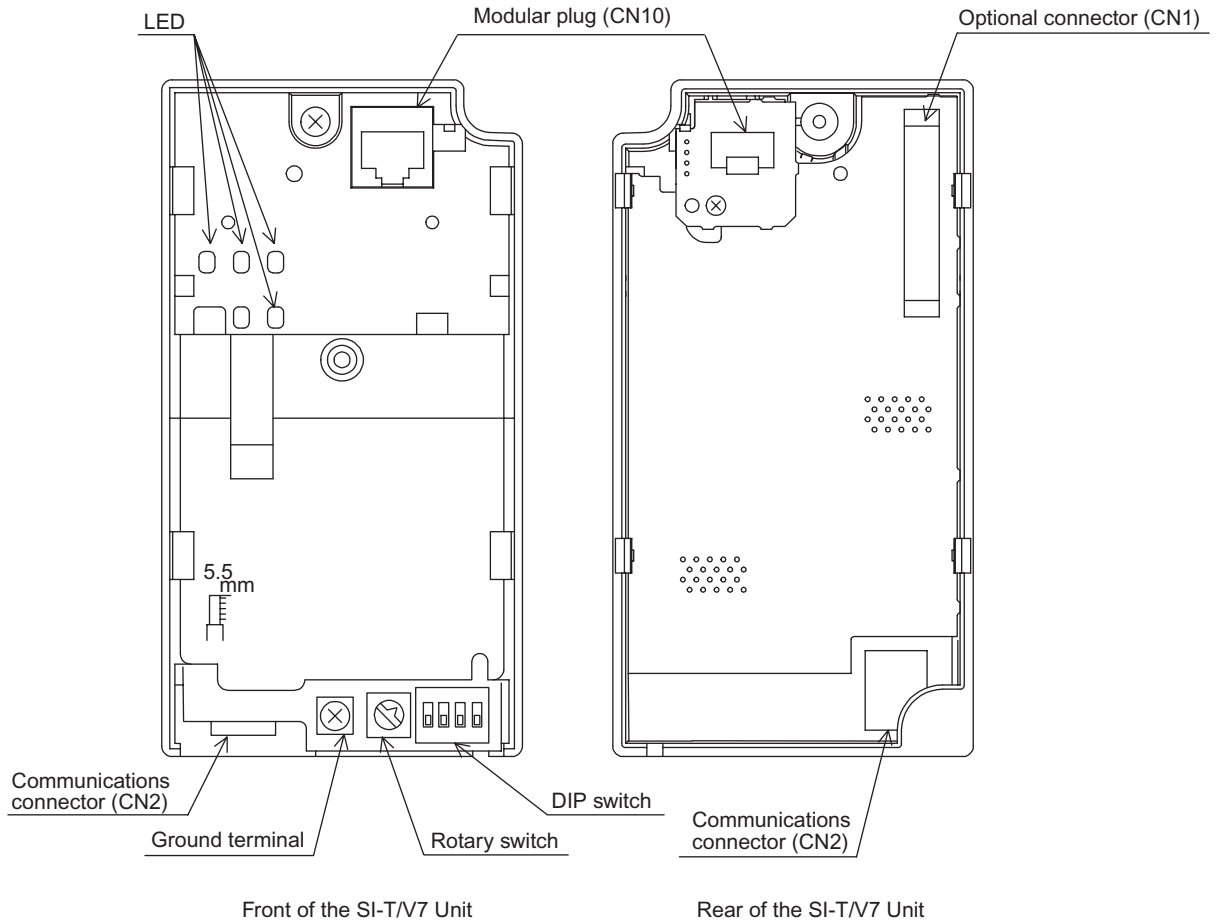

3.2 Communications Connectors (CN2)

The communications connectors connect the SI-T/V7 Unit to the communications lines of the MECHATROLINK-I or MECHATROLINK-II. The following table shows the pin numbers and their functions.

Pin No.	Signal Name	I/O	Function
A1	(NC)	–	Not used.
A2	SRD–	I/O	Send/receive data (-)
A3	SRD+	I/O	Send/receive data (+)
A4	(NC)	–	Not used.
B1	(NC)	–	Not used.
B2	SRD–	I/O	Send/receive data (-)
B3	SRD+	I/O	Send/receive data (+)
B4	(NC)	–	Not used.
Shell	Shield	–	Not used.

3.3 LED Indicators

The LED indicators indicate the status of the communications of the MECHATROLINK-I or MECHATROLINK-II and the SI-T/V7 Unit.

However, these indicators are for maintenance checks at Yaskawa. Use the Digital Operator to check the status.

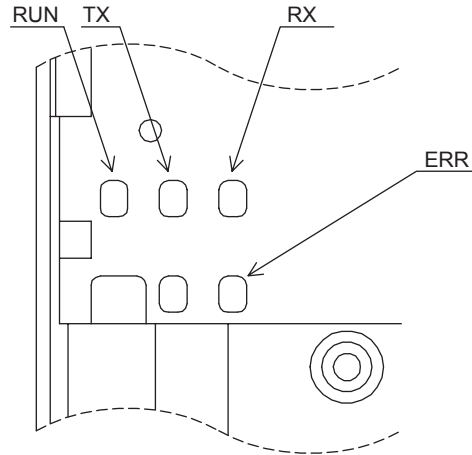

Name	Display		Explanation
	Color	Status	
RUN	Green	Lit	Normal operation
	–	Not lit	Communications CPU stopped, resetting hardware, RAM check error, DPRAM check error, station address setting error, or Inverter model code error
ERR	Red	Lit	Watchdog timeout error, communications error, or resetting hardware
	Red	Blinking	ROM check error (once)*, RAM check error (twice)*, DPRAM check error (3 times)*, communications ASIC self-diagnosis error (4 times)*, ASIC RAM check error (5 times)*, station address setting error (6 times)*, Inverter model code error (7 times)* *: Indicates the number of blinking.
	–	Not lit	No communications error or self-diagnosis error
TX	Green	Lit	Sending data
	–	Not lit	Sending of data stopped, hardware reset
RX	Green	Lit	Searching for receiving carrier
	–	Not lit	No receiving carrier found, resetting hardware

3.4 Switch Setting

■ DIP Switch

The following table shows the SI-T/V7 Unit DIP switch settings.

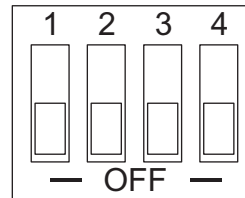

Name	Label	Status	Function	Factory Setting
Baud rate	S1-1	OFF	4 Mbps (MECHATROLINK-I)* ¹	ON
		ON	10 Mbps (MECHATROLINK-II)	
Data length	S1-2	OFF	17-byte data transmission (MECHATROLINK-I/MECHATROLINK-II)	ON
		ON	32-byte data transmission (MECHATROLINK-II)* ¹	
Station address	S1-3	OFF	Set the 10's digit of the station number to 2. Invalid if the maximum number of units including the S2 of the rotary switch is 20.	OFF
		ON	Set the 10's digit of the station number to 3. Invalid if the maximum number of units including the S2 of the rotary switch is 3F.	
Maintenance	S1-4	OFF	Normally OFF* ²	OFF
		ON	Not used.	

* 1. Invalid if S1-1 is OFF (4 Mbps) and S1-2 is ON (32-byte data transmission).

* 2. For maintenance. Always leave this switch OFF.

■ Rotary Switch

The following table shows the SI-T/V7 Units rotary switch settings.

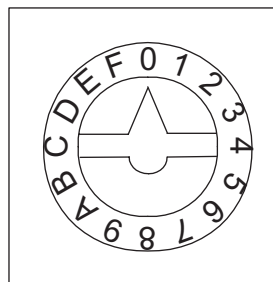

Label	Status	Function	Factory Setting
S2	0 to F	Set the 1's digit of the station number. Invalid if the maximum number of units including the S1-3 is 20 or 3F.	1

Note: Although the range that can be set by S1-3 and S2 is from 20 to 3F, 20 and 3F are invalid (the ERR LED indicator blinks six times).

Therefore, the actual setting range is from 21 to 3E.

Refer to the following section *Station-number Setting* for details.

■ Station-number Setting

A station number is set by both the S1-3 DIP switch and the S2 rotary switch. Station numbers from 21 to 3E are valid. Although 20 or 3F can be set as a station number, do not use these settings because they will be faulty.

S1-3: Set the 10's digit of the station number.

OFF = 2 (2X)

ON = 3 (3X)

S2: Set the 1's digit of the station number.

0 = 0 (X0)

1 = 1 (X1)

• •

• •

F = F (XF)

Switch Setting and Station Number

S1-3	S2	Station Number	S1-3	S2	Station Number
OFF	0	Fault	ON	0	30
OFF	1	21	ON	1	31
OFF	2	22	ON	2	32
OFF	3	23	ON	3	33
OFF	4	24	ON	4	34
OFF	5	25	ON	5	35
OFF	6	26	ON	6	36
OFF	7	27	ON	7	37
OFF	8	28	ON	8	38
OFF	9	29	ON	9	39
OFF	A	2A	ON	A	3A
OFF	B	2B	ON	B	3B
OFF	C	2C	ON	C	3C
OFF	D	2D	ON	D	3D
OFF	E	2E	ON	E	3E
OFF	F	2F	ON	F	Fault

4 Installation and Wiring

WARNING

- Before installing or performing wiring, always turn OFF the power to the Inverter and wait until the specified period of time has elapsed after all the Inverter indicators have turned OFF. (The time is shown on the Inverter's front cover.)

Failure to observe this warning may result in electric shock.

IMPORTANT

Route the MECHATROLINK communications cables separately from the main circuit wiring and other power lines.

4.1 Installing the SI-T/V7 Unit

Use the following procedure to mount the SI-T/V7 Unit after removing the Inverter's Digital Operator and front cover.

Be sure to complete the wiring to the Inverter before installing the SI-T/V7 Unit, because the terminals of the Inverter are hidden from view after the Unit is installed.

1. Turn OFF the Inverter's main-circuit power supply and wait one minute.
2. Confirm that all the indicators on the Inverter have turned OFF, wait until the specified period of time has elapsed (the time is shown on the Inverter's front cover), and then remove the Digital Operator and the front cover.
3. Use nippers to cut off the cover of the Inverter's CN2 connector in the three places-marked as A in Fig. 1. Be careful that the covers do not fall into the Inverter Unit. If pieces do fall in, be sure to remove them.
4. Align the mounting fixture with the C tab, and use $M3 \times 8$ SW screws to secure the fixture B.
5. Before installing the SI-T/V7 Unit on the Inverter, connect the grounding cable to the grounding terminal as shown in Fig. 2. Three types of grounding cables for various Inverter capacities are provided. Connect the appropriate cable with a crimp terminal.
6. When installing the SI-T/V7 Unit onto the Inverter Unit, make sure that it is straight. Align the modular plug (CN10) of the SI-T/V7 Unit with the modular plug (CN1) of the Inverter, and connector (CN2) with the connector for the SI-T/V7 Unit (CN2).
7. Tighten the screw at position D to affix the SI-T/V7 Unit to the Inverter Unit. The screw is already screwed in on the Inverter Unit.
8. Return the Digital Operator and the front cover to their original positions.

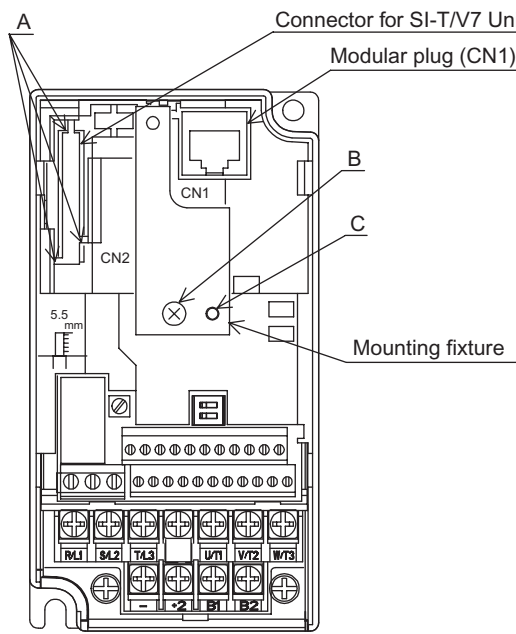

Fig. 1 Front of the Inverter

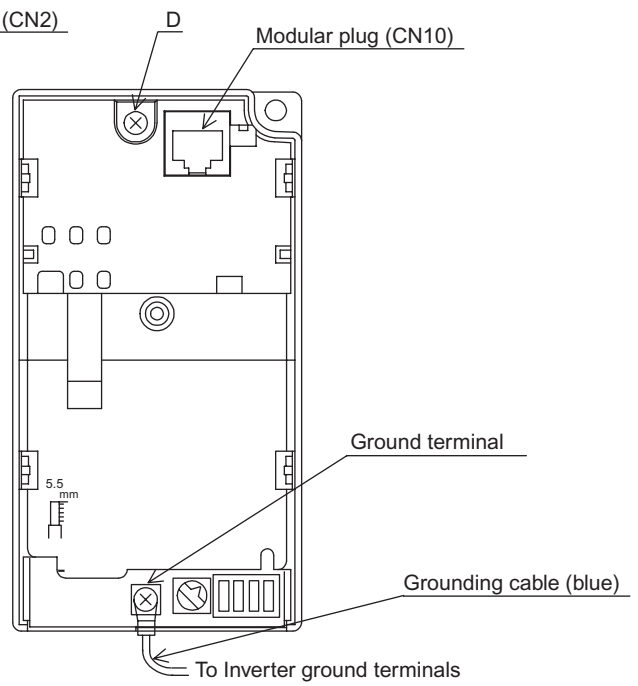

Fig. 2 Front of the SI-T/V7 Unit

4.2 MECHATROLINK Communications Cables

■ Wiring

Wire the MECHATROLINK communications cables to the communications connector (CN2).

IMPORTANT

- For communications cables, use special shielded twisted-pair cables for MECHATROLINK communications.
Recommended cable: JEPMC-W603-□□ *
* □□ is the length (m).
With USB male connector
- Install MECHATROLINK communications cables apart from main-circuit wiring and other electrical and power lines.
- Connect the terminator (model No.: JEPMC-W6022) on the end of the communication lines.
- Maximum transmission distance is 50 m.
- Minimum wiring distance between stations is 0.5 m.

■ Communications Wiring Example

The following diagram is an example of communications wiring around the Inverters.

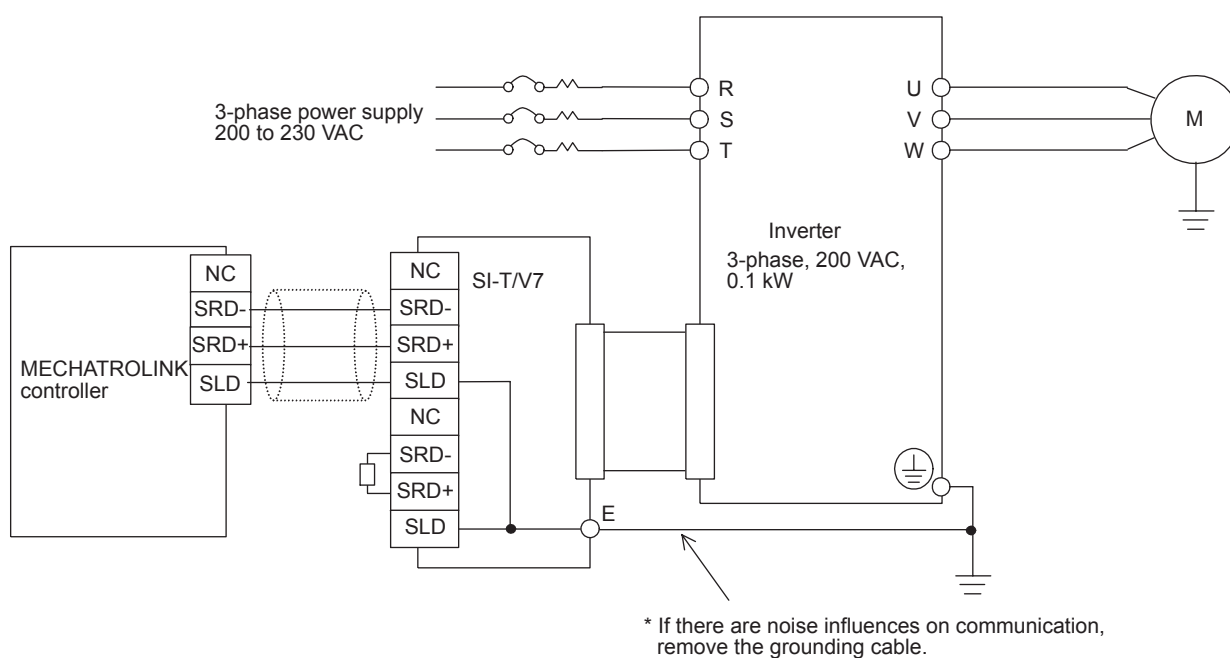
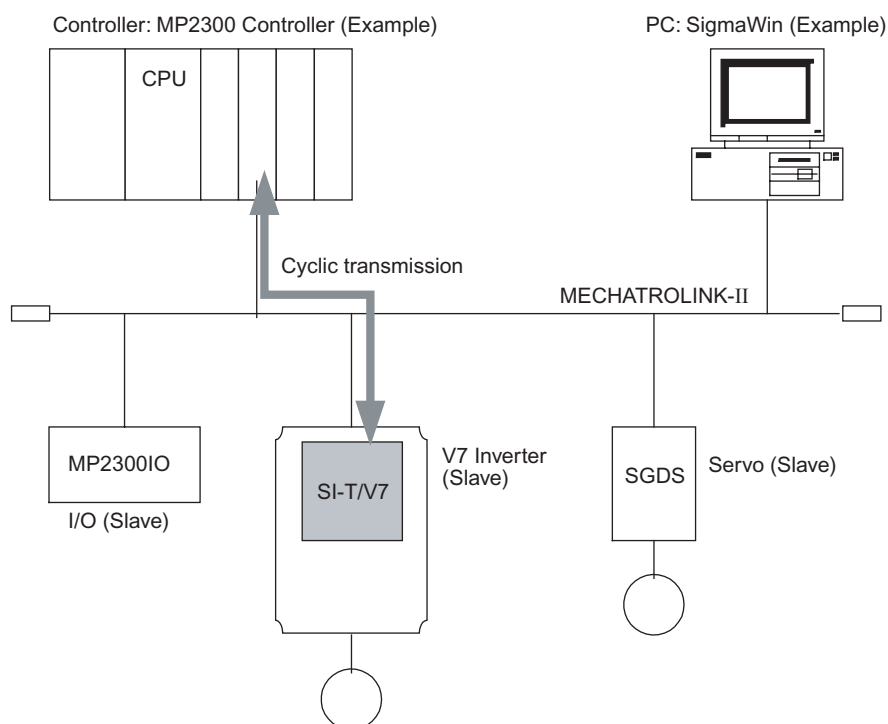

Fig. 3 Connection Diagram with VS mini (3-phase, 200 VAC, 0.1kW)

5 Transmission Interface

5.1 MECHATROLINK-II Cyclic Transmissions

As a MECHATROLINK-I/MECHATROLINK-II slave, the SI-T/V7 exchanges control data and I/O data with a control device, such as a controller. Communications with the controller are executed by sending response data timed to the reception of command data for the local station address from the controller in each transmission cycle. The formats for the command and response data follow the specifications for the MECHATROLINK Inverter commands.



5.2 Basic Format of Data Transfer

The basic format for transferring data is as follows.

The size of the header for a data link layer is fixed at two bytes.

By setting pin 2 on DIP switch S1, either 17 bytes (17-byte mode) or 32 bytes (32-byte mode) can be selected as the data size for the data link layer. If 32-byte mode is selected, only the first 29 bytes are used as application data.

* The first 30 bytes are used only when the INV_I/O sub-command is used.

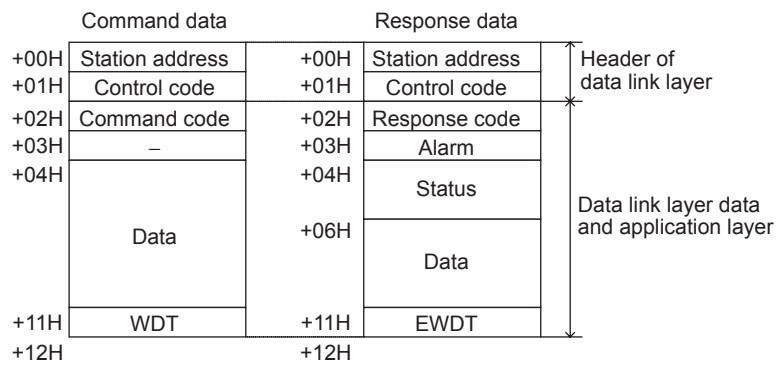

Basic format of data transfer (17-byte mode)

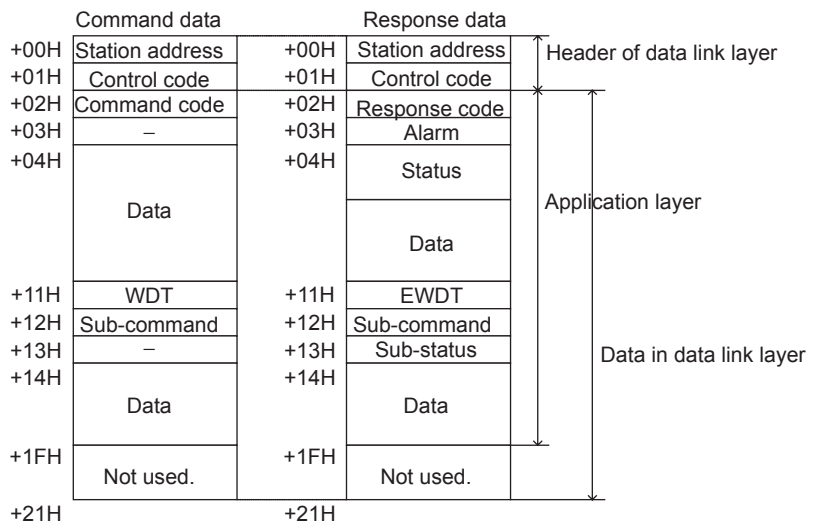

Basic format of data transfer (32-byte mode)

5.3 Communications Phases

The SI-T/V7 changes status as described here when a command code or fault is received from the master.

For details on MECHATROLINK communications phases, refer to the *High-speed Field Network MECHATROLINK System User's Manual* (SIE-S800-26.1).

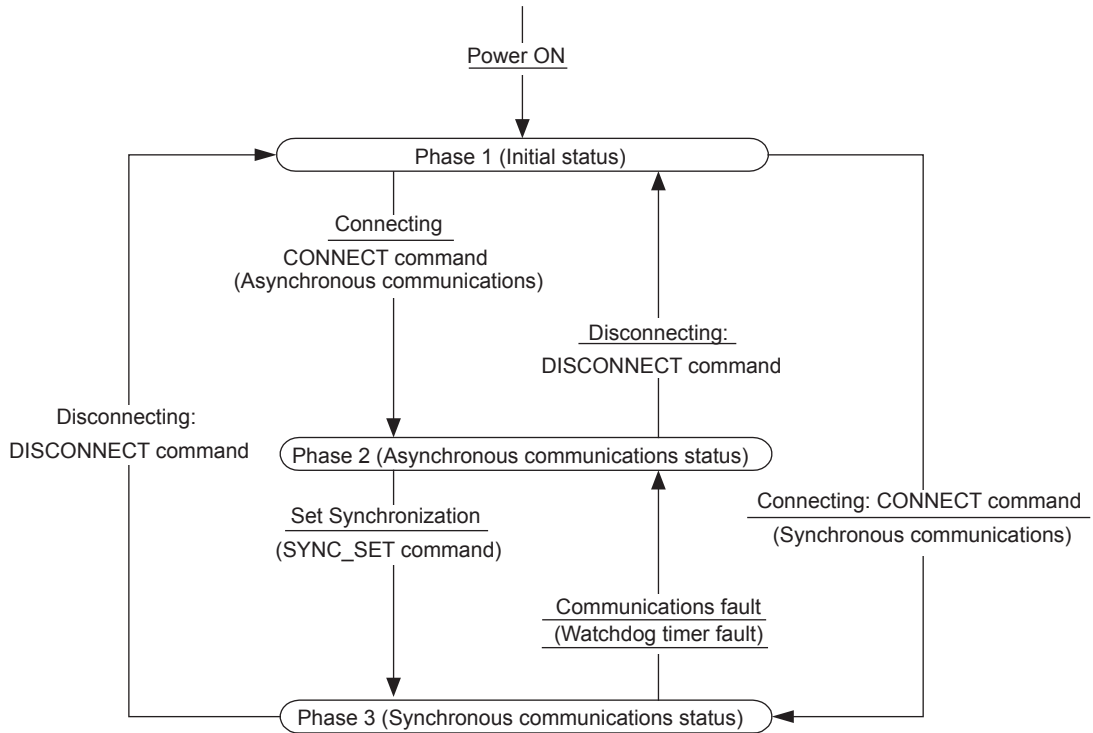

Phase 1: Initial status after power ON

Operation proceeds with a default transmission cycle of 2 ms. The transmission cycle is changed to the time indicated in the synchronous frame when a CONNECT command is received from the master. Then the phase moves to phase 2 or phase 3 after a response to the CONNECT command is returned.

Even if a transfer fault is detected in phase 1, no fault notification is provided.

Phase 2: Asynchronous communications

All SI-T/V7 commands can be used. Phase 2 starts to count the watchdog timer in the communications frame. The phase moves to phase 3 when a SYNC_SET command is received, and it moves to phase 1 when a DISCONNECT command is received.

Phase 3: Synchronous communications

Watchdog timer faults in the communications frame are detected. If the DISCONNECT command is received, the phase moves to phase 1. If a reception fault or a watchdog timer fault is detected, the phase moves to phase 2.

5.4 Application Layer Specifications

The data format for the application layer conforms to the MECHATROLINK-II link command specifications. The SI-T/V7 has the following main commands and sub-commands.

Table 1 Main Commands

Name	Function
NOP	No Operation
PRM_RD	Reads Parameters.
PRM_WR	Writes Parameters.
ID_RD	Reads ID numbers.
CONFIG	RAM Write ENTER_CODE and EEPROM Write ENTER_CODE
ALM_RD	Reads fault and alarm.
ALM_CLR	Clears fault and alarm.
CONNECT	Connect
DISCONNECT	Disconnect
INV_CTL	Controls Inverter Operation.
SYNC_SET	Starts Synchronous Communications.

Table 2 Sub-commands

Name	Function
NOP	No operation
PRM_RD	Reads Parameters.
PRM_WR	Writes Parameters.
ALM_RD	Reads fault and alarm.
INV_I/O	Controls Inverter I/O.

The main commands are used in both the 17-byte and 32-byte modes for MECHATROLINK-II and with MECHATROLINK-I. The sub-commands can be used only when the 32-byte mode has been selected by means of pin 2 on DIP switch S1. If a conflict occurs between a request for a main command and a request for a sub-command, the request for the main command is processed. If either a main command or a sub-command is already being processed, the command being processed is given priority. If an INV_CTL main command and an INV_I/O sub-command conflict, the sub-command overwrites the main command.

For details on command formats, refer to *Chapter 7 MECHATROLINK-II Commands*.

6 Initial Setup

Before starting communications between the Inverter and the MECHATROLINK master, set the following constants as required.

Constant No.	Name	Description	Default
n003	Operation Method Selection	0: Digital Operator 1: Control-circuit terminal 2: MEMOBUS communications 3: Communications Card (optional)	0
n004	Frequency Reference Selection	0: Digital Operator 1: Frequency reference 1 (n024) 2: Control circuit terminal (0 V to 10 V) 3: Control circuit terminal (4 mA to 20 mA) 4: Control circuit terminal (0 mA to 20 mA) 5: Pulse train 6: MEMOBUS communications 7: Digital Operator circuit terminal (0 to 10 V) 8: Digital Operator circuit terminal (4 to 20 mA) 9: Communications Card (optional)	0

* If running or stopping the Inverter from MECHATROLINK, set n003 to 3. If setting the frequency from MECHATROLINK, set n004 to 9. For details, refer to the *VS-606 V7 Series Instruction Manual (TOE-S606-11)*.

7 MECHATROLINK-II Commands

7.1 Main Commands

The format of the main commands are as follows.

■ No Operation (NOP)

Byte	Command	Response
1	NOP	NOP
2		ALARM
3		STATUS
4		
5		
6		
7		
8		
9		
10		
11		
12		
13		
14		
15		
16	WDT	RWDT

Only the ALARM and STATUS fields of the response data can be monitored.

This command can be used in all phases.

■ Read Parameter (PRM_RD)

Byte	Command	Response
1	PRM_RD	PRM_RD
2		ALARM
3		STATUS
4		
5	NO	NO
6		
7	SIZE	SIZE
8		PARAMETER
9		
10		
11		
12		
13		
14		
15		
16	WDT	RWDT

The PRM_RD command is used to read the Inverter's internal constants. For offline parameters, it reads the most recently updated setting values.

This command can be used in all phases.

Note: If the MECHATROLINK-II 32-byte mode is used, PRM_RD can be used only in a sub-command.

In the following cases, a warning (STATUS (WARNING) = 1) is generated and the command is ignored. If a warning is generated, the values that are read are undefined.

- While using the Digital Operator to change settings: Command alarm (A.95)
- If received as a main command in 32-byte mode: Command alarm (A.95)
- If a register number (NO) fault occurs: User constant setting alarm (A.94)
- If SIZE is an odd number or is not between 2 and 8: User constant setting alarm (A.94)

The register number (NO) is the same as the register number that is set and referenced in MEMOBUS transfers. Set the lower byte (LSB) before setting the upper byte (MSB).

The SI-T/V7 stores the data read for PARAMETER from lower byte (LSB) to upper byte (MSB).

For SIZE, set the number of bytes to be read as an even numbers. Eight bytes can be specified.

The values for the number (NO) and the size (SIZE) in the response are copies of the values in the command.

■ Write Parameter (PRM_WR)

Byte	Command	Response
1	PRM_WR	PRM_WR
2		ALARM
3		STATUS
4		
5	NO	NO
6		
7	SIZE	SIZE
8	DATA	DATA
9		
10		
11		
12		
13		
14		
15		
16	WDT	RWDT

The PRM_WR command is used to write the Inverter's internal constants.

To save the setting value in the Inverter's EEPROM, set the CONFIG_MOD in the CONFIG command to 1. For details, refer to the section describing the CONFIG command.

Note: If the MECHATROLINK-II 32-byte mode is used, PRM_WR can be used only in a sub-command.

In the following cases, a warning is generated and the command is ignored.

- While using the Digital Operator to change settings: Command alarm (A.95)
- If not in phase 2: Command alarm (A.95)
- During an undervoltage fault: Command alarm (A.95)
- If received as a main command in 32-byte mode: Command alarm (A.95)
- If a register number (NO) fault occurs: User constant setting alarm (A.94)
- If SIZE is an odd number or is not between 2 and 8: User constant setting alarm (A.94)
- Data upper/lower limit fault: User constant setting alarm (A.94)

The register number (NO) is the same as the register number that is set and referenced in MEMOBUS transfers.

Set the lower byte (LSB) before setting the upper byte (MSB).

Set the values for DATA from lower byte (LSB) to upper byte (MSB).

For SIZE, set the number of bytes to be written as an even number. Eight bytes can be specified.

The values for the NO, SIZE, and DATA in the response are copies of values in the command.

■ Read ID (ID_RD)

Byte	Command	Response
1	ID_RD	ID_RD
2		ALARM
3		STATUS
4		
5	DEVICE_CODE	DEVICE_CODE
6	OFFSET	OFFSET
7	SIZE	SIZE
8		ID
9		
10		
11		
12		
13		
14		
15		
16	WDT	RWDT

The ID_RD command is used to read the ID number.

The following table shows the applicable DEVICE_CODE.

Because of ID area limitations, no more than eight bytes can be read, so use the OFFSET and SIZE to specify the range.

The leading ID data that corresponds to the specified OFFSET and returned is shown in the following table.

Up to eight bytes can be used for SIZE.

This command can be used in all phases.

	DEVICE_CODE	ID content*6															
	OFFSET	00	01	02	03	04	05	06	07	08	09	0A	0B	0C	0D	0E	0F
Inverter Model	00H	C	I	M	R	–	V	7	*1	2	0	P	1				
Software Version	02H			S	1	2	3	4		S	5	6	7	8			
				*4	*4	*4	*4	*4		*5	*5	*5	*5	*5			

* 1. The A and U portions of special Inverter models V7A and V7U, as well as the portions showing the structure are represented by spaces.

* 2. Indicates the voltage class. 2: 200-VAC input; 4: 400-VAC input

* 3. Indicates the maximum applicable motor capacity. For 0.1 kW, 0P1 is shown.

* 4. Indicates the SI-T/V7 software code.

* 5. Indicates the Inverter software code.

* 6. Inverter models are expressed in ASCII, and end in 00H.

■ Write RAM ENTER_CODE/Write EEPROM ENTER_CODE (CONFIG)

Byte	Command	Response
1	CONFIG	CONFIG
2		ALARM
3		STATUS
4		
5		CONFIG_MOD
6		
7		
8		
9		
10		
11		
12		
13		
14		
15		
16	WDT	RWDT

The CONFIG command are used to enable the data for which constants have been written.

Error codes such as matching of constants cannot be checked by the responses to this command. They must be checked with the STATUS signal's OPE fault bit.

This command can be used in phases 2 and 3.

In the following cases, a warning is generated and the command is ignored.

- If not in phase 2 or 3: Command alarm (A.95)
- If CONFIG_MOD is not a set value: Data setting alarm (A.94)

The following values can be assigned to CONFIG_MOD.

CONFIG_MOD	Description
0	Not required. The setting value is enabled after PRM_WR is executed.
1	The setting value is saved in EEPROM. Note: With the V7, the maximum number of writes to non-volatile memory is 100,000, so do not use the CONFIG command too frequently. If changing several constants, carry out the CONFIG command only after all the constants have been changed.

■ Read Alarm or Warning (ALM_RD)

Byte	Command	Response
1	ALM_RD	ALM_RD
2		ALARM
3		STATUS
4		
5		ALM_RD_MOD
6		ALM_DATA
7		
8		
9		
10		
11		
12		
13		
14		
15		
16	WDT	RWDT

The ALM_RD command is used to read the following information about the status of faults and alarms.

- Present fault and alarm status list
- Fault history (Alarms are not saved in the history.)
- Details of faults

In the following case, a warning is generated and the command is ignored.

- If ALM_RD_MOD is other than a set value: Data setting alarm (A.94)

The fault history is saved in EEPROM and is kept even when the control power is interrupted.

The following table shows the specifications for ALM_RD_MOD and ALM_DATA.

If the fault history (ALM_RD_MOD = 1) is selected, the fault code (1 byte) is entered in order of detection from ALM_DATA byte 6, and byte 6 is refreshed with the most recent fault code. If no fault occurred, 00H is displayed to indicate normal operations.

ALM_RD_MOD	ALM_DATA	Max. Processing Time	Constant No.
0	Present fault (byte 6), past fault (byte 7)	0.1 s	n178 (Fault History)
1	Fault history (Alarms are not retained in the history.) 2 max. (bytes 6 and 7)*	0.1 s	n178

■ Clear Alarm or Warning (ALM_CLR)

Byte	Command	Response
1	ALM_CLR	ALM_CLR
2		ALARM
3		STATUS
4		
5	ALM_CLR_MOD	ALM_CLR_MOD
6		ALM_DATA
7		
8		
9		
10		
11		
12		
13		
14		
15		
16	WDT	RWDT

The ALM_CLR command is used to clear the alarm and warning status.

This command changes the status of the slave station. It does not remove the cause of a fault. After the cause of the alarm or warning has been removed, this command is then used to clear the status of the alarm or warning.

In the following cases, a warning is generated and the command is ignored.

- If not in phase 2 or 3: Command alarm (A.95)
- If ALM_CLR_MOD is other than a set value: Data setting alarm (A.94)

ALM_CLR_MOD	Description
0	Clears the status of present faults and alarms.

Note: Inverter alarms cannot be reset while the Inverter RUN command is ON.

■ MECHATROLINK-II Connection (CONNECT)

Byte	Command	Response
1	CONNECT	CONNECT
2		ALARM
3		STATUS
4		
5		VER
6	COM_MOD	COM_MOD
7	COM_TIM	COM_TIM
8		
9		
10		
11		
12		
13		
14		
15		
16	WDT	RWDT

The CONNECT command is used to set the communications mode and establish a connection. After the connection is established, the phase moves to phase 2.

If a transfer fault is detected after moving to phase 2 or phase 3, notification is given of the fault. In phase 1, no notification is given even if a transfer fault is detected.

Set VER (version) to 21H (Ver. 2.1) for MECHATROLINK-II, and to 10H (Ver. 1.0) for MECHATROLINK-I. This setting must match the switch setting.

The communications mode is set by the COM_MOD. For details on the settings, refer to the following description.

- MECHATROLINK-II (VER: 21H)

Set the factor of the transmission cycle to COM_TIM (communications time) so that the setting range satisfies the following formulas.

When the transmission cycle is equal to the communications time (COM_TIM=1):

- 32-byte data transmission

$$1 \text{ [ms]} \leq \text{transmission cycle [ms]} \leq 8 \text{ [ms]}$$

If the transmission cycle is set to a fractional value, a warning (data setting alarm: A.94) is generated.

- 17-byte data transmission

$$0.5 \text{ [ms]} \leq \text{transmission cycle [ms]} \leq 8 \text{ [ms]}$$

If the transmission cycle is not set to a multiple of 0.5 ms, such as 0.75, a warning (data setting alarm: A.94) is generated.

When the transmission cycle is not equal to the communications time (1 < COM_TIM ≤ 32):

$$2 \text{ [ms]} \leq \text{transmission cycle [ms]} \times \text{COM_TIM} \leq 100 \text{ [ms]}$$

If the transmission cycle is less than 2 ms and is set to a fractional value, a warning (data setting alarm: A.94) is generated. If the communications cycle is set to a fractional value, a warning (data setting alarm: A.94) is generated.

- **MECHATROLINK-I (VER: 10H)**

Set the factor of the 2 ms transmission cycle to COM_TIM (communications time).

The setting range satisfies the following formulas.

$$2 \text{ [ms]} \leq \text{COM_TIM} \leq 64 \text{ [ms]}$$

COM_TIM is multiplied by a factor of 2.

In the following cases, a warning is generated and the command is ignored. Commands are also ignored in phase 2 (with no alarm).

- If COM_MOD is set out of range: Data setting alarm (A.94)
- If COM_TIM is set out of range: Data setting alarm (A.94)
- If SUBCMD is set to 1 in 17-byte mode: Data setting alarm (A.94)
- If SUBCMD is set to 1 for Ver. 1.0 (VER: 10H): Data setting alarm (A.94)
- If D6, D5, D4, D3, or D0 is set to 1: Data setting alarm (A.94)

For details on the transmission cycle, communications time, and communications phases, refer to the *High-speed Field Network MECHATROLINK System User's Manual* (SIE-S800-26.1).

COM_MOD

D7	D6	D5	D4	D3	D2	D1	D0
SUBCMD	0	0	0	DTMOD		SYNCMOD	0

Note: If D6, D5, D4, or D0 is set to 1, a warning will be generated (data setting alarm: A.94).

SUBCMD

0: Sub-command not used.

1: Sub-command used.

Note: With MECHATROLINK (VER: 10H), SUBCMD is fixed at 0.

DTMOD (Data Transfer Mode)

00: Single data transfer mode

10/11: Data setting alarm (A.94)

SYNCMOD (Synchronous/Asynchronous Communications)

0: Asynchronous communications. Move to phase 2.

1: Synchronous communications. Move to phase 3.

■ Disconnection (DISCONNECT)

Byte	Command	Response
1	DISCONNECT	DISCONNECT
2		ALARM
3		STATUS
4		
5		
6		
7		
8		
9		
10		
11		
12		
13		
14		
15		
16	WDT	RWDT

The DISCONNECT command is used to close the connection and move to phase 1.

After moving to phase 1, no check for transmission faults is executed.

This command can be used in phases 2 and 3.

If this command is received while in phase 2 or 3, the data for the control command to the Inverter is cleared to 0, and a fault reset command is carried out for the Inverter.

■ Inverter Control (INV_CTL)

Byte	Command	Response
1	INV_CTL	INV_CTL
2		ALARM
3	Operation signals	STATUS
4		
5	Speed reference	Output frequency
6		
7	Torque reference (torque limit)	Output current
8		
9	SEL REF1/2	SEL REF1/2
10	SEL MON1/2	SEL MON1/2
11	Reference selected by SEL REF1	Monitor selected by SEL MON1
12		
13	Reference selected by SEL REF2	Monitor selected by SEL MON2
14		
15		
16	WDT	RWDT

The INV_CTL command is used to set the Inverter's operation signals, speed references, and so on.

These bytes do not need to be set every scan. The settings are saved in the Inverter until the next data is received or until the power is turned OFF.

For details on operation signals, refer to the following table.

The speed reference unit can be selected with n035.

The torque reference is used for both positive and negative values, in units of 0.1%.

Table 3 Operation Signals

Bit	Description	Remarks
0	Forward operation	
1	Reverse operation	
2	INV multi-function terminal input 3	Default: External fault (EF3)
3	INV multi-function terminal input 4	Default: Fault reset
4	INV multi-function terminal input 5	Default: Multi-step speed reference 1
5	INV multi-function terminal input 6	Default: Multi-step speed reference 2
6	INV multi-function terminal input 7	Default: Jog command
7	Not used.	
8	External fault (EFO)	
9	Fault reset ^{*1*2}	
A	Not used.	
B	Not used.	
C	Not used.	
D	Not used.	
E	Fault history trace clear	
F	External BB command	

* 1. Check that the faults has been successfully reset by confirming that the STATUS (RESET) bit has turned OFF.

* 2. Errors are not reported while the fault reset signal is ON.

Use the SEL REF1/2 command to select the contents of REF1 with bits 0 to 3 and to select the contents of REF2 with bits 4 to 7.

Use the SEL MON1/2 command to select the contents of MON1 with bits 0 to 3 and to select the contents of MON2 with bits 4 to 7.

The following tables show the selection ranges for SEL REF1/2 and SEL MON1/2.

Table 4 SEL REF1/2 Selection Range

REF1/2	Item	Remarks
0	Nothing selected	
1	Not used.	
2	Not used.	
3	Not used.	
4	INV terminal output: Bit 0: Terminals MA-MB (Enabled when n057 = 18) Bit 1: Terminal P1 (Enabled when n058 = 18) Bit 2: Terminal P2 (Enabled when n059 = 18)	
5 to F	Not used.	The SI-T/V7 ignores the written data.

Table 5 SEL MON1/2 Selection Range

REF1/2	Item	Remarks
0	Nothing selected.	
1	Output frequency According to n035.	
2	Torque reference (U-08): 0.1 % Given only for vector control.	
3	Not used.	
4	Frequency reference (U-01) According to n035.	
5	Pulse train reference RP: 0.1 %	
6	Main circuit current voltage: 1 V	
7	Inverter alarm	Refer to the Inverter alarm code list.
8	Inverter warning	Refer to the Inverter warning code list.
9	Not used.	
A	Not used.	
B	INV terminal DI input Bits 0 to 7: Terminals S1 to S7	
C	INV analog input FR: 0.1 %	
D	Not used.	
E, F	Not used.	Always 0.

In the following case, a warning is generated and the command is ignored.

- If not in phase 2 or 3: Command fault (A.95)

■ Start Synchronous Communications (SYNC_SET)

Byte	Command	Response
1	SYNC_SET	SYNC_SET
2		ALARM
3		STATUS
4		
5		
6		
7		
8		
9		
10		
11		
12		
13		
14		
15		
16	WDT	RWDT

The SYNC_SET command is used to request the start of synchronous communications. After this command is issued, synchronous communications are carried out. If communications become asynchronous due to any fault such as a communications fault, this command can be used to restore synchronous communications.

In the following case, a warning is generated and the command is ignored.

- If not in phase 2 or 3: Command fault (A.95)

7.2 Sub-commands

The format of sub-commands are as follows. Sub-commands can be used only with MECHATROLINK-II when the 32-byte mode has been selected by a switch.

■ No Operation (NOP)

Byte	Command	Response
17	NOP	NOP
18		SUBSTATUS
19		
20		
21		
22		
23		
24		
25		
26		
27		
28		
29		

This is the format of No Operation sub-command.

■ Read Parameter (PRM_RD)

Byte	Command	Response
17	PRM_RD	PRM_RD
18		SUBSTATUS
19	NO	NO
20		
21	SIZE	SIZE
22		PARAMETER
23		
24		
25		
26		
27		
28		
29		

The PRM_RD sub-command is used to read internal Inverter constants.

This sub-command functions in the same way as the PRM_RD main command.

In the following cases, a warning is generated and the command is ignored. If a warning is generated, the values that were read are undefined.

- While using the Digital Operator to change settings: Command alarm (A.95)
- If a register number (NO) fault occurs: User constant setting alarm (A.94)
- If SIZE is an odd number or is not between 2 and 8: User constant setting alarm (A.94)

■ Write Parameter (PRM_WR)

Byte	Command	Response
17	PRM_WR	PRM_WR
18		SUBSTATUS
19	NO	NO
20		
21	SIZE	SIZE
22	PARAMETER	PARAMETER
23		
24		
25		
26		
27		
28		
29		

The PRM_WR sub-command is used to write internal Inverter constants.

This sub-command functions in the same way as the PRM_WR main command.

In the following cases, a warning is generated and the command is ignored. If a warning is generated, the values that were read are undefined.

- While using the Digital Operator to change settings: Command alarm (A.95)
- If not in phase 2 or 3: Command fault (A.95)
- During an undervoltage error: Command alarm (A.95)
- If a register number (NO) fault occurs: User constant setting alarm (A.94)
- If SIZE is an odd number or is not between 2 and 8: User constant setting alarm (A.94)
- Data upper and lower limit fault: User constant setting alarm (A.94)

■ RAM Write ENTER_CODE/EEPROM Write ENTER_CODE (CONFIG)

Byte	Command	Response
17	CONFIG	CONFIG
18		SUBSTATUS
19	CONFIG_MOD	CONFIG_MOD
20		
21		
22		
23		
24		
25		
26		
27		
28		
29		

The CONFIG command is used to enable data for which constants have been written. This sub-command functions in the same way as the CONFIG main command.

In the following cases, a warning is generated and the command is ignored.

- If CONFIG_MOD is not set: Data setting value alarm (A.94)
- If not in phase 2 or 3: Command fault (A.95)

■ Read Alarm (ALM_RD)

Byte	Command	Response
17	ALM_RD	ALM_RD
18		SUBSTATUS
19	ALM_RD_MOD	ALM_RD_MOD
20		ALM_DATA
21		
22		
23		
24		
25		
26		
27		
28		
29		

The ALM_RD sub-command is used to read the fault and alarm status.

This sub-command functions in the same way as the ALM_RD main command.

In the following case, a warning is generated and the command is ignored.

- If ALM_RD_MOD is not set: Data setting alarm (A.94)

■ Inverter I/O Control (INV_I/O)

Byte	Sub-Command	Response
17	INV_I/O	INV_I/O
18		SUBSTATUS
19	SEL REF3/4	SEL REF3/4
20	SEL REF5/6	SEL REF5/6
21	SEL MON3/4	SEL MON3/4
22	SEL MON5/6	SEL MON5/6
23	Reference selected by SEL REF3.	Monitor selected by SEL MON3.
24		
25	Reference selected by SEL REF4.	Monitor selected by SEL MON4.
26		
27	Reference selected by SEL REF5.	Monitor selected by SEL MON5.
28		
29	Reference selected by SEL REF6.	Monitor selected by SEL MON6.
30		

The INV_I/O sub-command is used to select the type of output from the Inverter's external terminals and refers to the values from the Inverter's internal monitors.

These settings do not need to be set every scan. The settings are saved in the Inverter until the next data is received or until the power is turned OFF.

The output from the Inverter's external terminals is enabled when the multi-function input is set to not be used.

The SEL REF3/4 sub-command is used to select the contents of REF3 with bits 0 to 3, and select the contents of REF4 with bits 4 to 7.

The SEL REF5/6 sub-command is used to select the contents of REF5 with bits 0 to 3, and select the contents of REF6 with bits 4 to 7.

The selection range for SEL REF3 to 6 is the same as that for the SEL REF1/2 command in the INV_CTL main command.

The SEL MON3/4 sub-command is used to select the contents of MON3 with bits 0 to 3, and select the contents of MON4 with bits 4 to 7.

The SEL MON5/6 sub-command is used to select the contents of MON5 with bits 0 to 3, and select the contents of MON6 with bits 4 to 7.

The selection range for SEL MON3 to 6 is the same as that for the SEL MON1/2 command in the INV_CTL main command.

In the following cases, a warning is generated and the command is ignored.

- If not in phase 2 or 3: Command fault (A.95)

7.3 Status Details

This section describes the STATUS field for main commands and the SUBSTATUS field for sub-commands.

■ STATUS Field

Bit	Name	Description	Value	Setting
0	ALM	Alarm status	0	No alarm
			1	Alarm (fault)
1	WARNG	Warning status	0	No warning
			1	Warning
2	CMDRDY	Command ready	0	Busy
			1	Ready
3	BB OFF	Baseblock OFF (OFF when output voltage is being output from the Inverter or during baseblock.)	0	Baseblock ON
			1	Baseblock OFF
4	PON	Main power supply ON (OFF during undervoltage)	0	Main power supply OFF
			1	Main power supply ON
5	RUNX	Running	0	
			1	Running
6	0SP	Zero speed	0	
			1	Zero speed
7	REV	Reverse RUN	0	Forward RUN
			1	Reverse RUN
8	RESET	Fault reset signal input	0	
			1	Fault reset signal input
9	AGREE	Speed agreement	0	
			1	Speed agreement
A	INV_READY	Inverter ready	0	
			1	Inverter ready
B	OPE	OPE fault	0	
			1	OPE fault
C	UV_R	Recovery after power loss or recovery after momentary power loss	0	Recovery after power loss
			1	Recovery after momentary power loss
D	REMOTE	Local or Remote	0	Local
			1	Remote (Transfer)
E	-	Not used.	0	
			1	
F	-	Not used.	0	
			1	

* With the MEM_RD command, only the settings for the STATUS (CMDRDY) is valid. Other bits are not used.

■ SUBSTATUS Field

18th Byte

D7	D6	D5	D4	D3	D2	D1	D0
–	–	–	–	–	SUBCMDRDY	SBWARNG	SBALM

Bit	Name	Description	Value	Setting
D0	SUBALM	Sub-command alarm	0	No alarm
			1	Alarm
D1	SUBWARNG	Sub-command warning	0	No warning
			1	Warning
D2	SUBCMDRDY	Sub-command ready (Sub-command can be received.)	0	Busy
			1	Ready

Note: D3 to D7 are not used. A value of 0 is always returned.

8 Protective Operations

8.1 Fault Detection Processing

Faults can be detected by two methods: Inverter fault detection and SI-T/V7 fault detection.

The SI-T/V7 is notified of Inverter faults by the internal interface, and the SI-T/V7 sends the response data, ALARM or STATUS.

The SI-T/V7 notifies Inverter of SI-T/V7 faults by the internal interface, and the faults are simultaneously sent the response data, ALARM or STATUS.

The following four types of faults can be detected. The subsequent operation varies depending on the type of fault.

Fault Type		Description	Location
Alarm	Inverter alarm	Major fault that causes damage to the Inverter or machinery	Inverter
	Communications alarm	Interference related to MECHATROLINK-II communications	SI-T/V7
Warning	Inverter warning	Illegal operation or minor fault not posing any immediate danger	Inverter
	Communications warning	MECHATROLINK-II communications fault warning	SI-T/V7

Fault Type	SI-T/V7 Processing				Direction of Communications	Reset	
	MECHATROLINK Response			LED2 Status			Processing
	ALARM	STATUS					
		WARNG	ALM				
Inverter alarm	CODE	–	1	–	No special processing	←	Required
Communications alarm	CODE	–	1	Lit	Notification to Inverter	①→ ←②	Required
Inverter warning	CODE	1	–	–	No special processing	←	Required
Communications warning	CODE	1	–	–	No special processing	None	Not required

Note: The meanings of each symbol are as follows.

- : No change
- : Fault notification to Inverter
- ←: Fault notification from Inverter

When consecutive alarms occur, the SI-T/V7 provides notification of the most recent alarm with a MECHATROLINK response data. If warnings occur simultaneously, notification priority is given to the warning with the lowest warning code. If alarms and warnings are mixed together, the SI-T/V7 gives notification priority to alarms.

The following table shows the response data when consecutive alarms or warnings occurs.

Table 6 Response Data for Consecutive Alarms and/or Warnings

Fault Detection		MECHATROLINK-II Response Data Contents		
Previous Value	Most Recent Value	Alarm	STATUS	
			WARNG	ALM
Alarm	Alarm	Most recent alarm code	0	1
Alarm	Warning	Most recent alarm code	1	1
Warning	Alarm	Most recent alarm code	1	1
Warning	Warning	Warning with the smaller warning code	1	0

8.2 Alarm Processing

■ SI-T/V7 Communications Fault Detection

The following tables show the communications faults detected by the SI-T/V7 and the conditions in which they can be detected.

Table 7 Reception Failures in Each Phase

Communications Phase	Reception Failure		Transmission cycle
	First	Second (Consecutive)	Fault
Phase 1	–	–	–
Phase 2	96	E6	E6
Phase 3	96	E6	E6

Table 8 Alarm Code (MECHATROLINK-II Response ALARM Value)

ALARM	Description	Fault Type
96	MECHATROLINK-II communications fault warning	Communications warning
E5	MECHATROLINK-II WDT fault	Communications alarm
E6	MECHATROLINK-II communications fault	Communications alarm

Table 9 Fault Types

Fault	Description
Communications failure	Transmission LSI detected a data reception failure.
Transmission cycle fault	A timing fault of a synchronous frame in a transmission cycle was detected.
Watchdog timer fault	A WDT count fault in a synchronous frame was detected.

■ Other Faults

The following table shows other faults that can be detected by the SI-T/V7.

If a warning occurs, operation will follow the previous command.

ALARM	Description	Fault Type	Operation when Fault Occurs
94	Data setting warning	Communications warning	Received commands are ignored.
95	Command warning	Communications warning	Received commands are ignored.
EC	WDC fault with Inverter	Communications alarm	Waits for power supply to be reset.
ED	Inverter access permission fault (Access not possible 10 consecutive times)	Communications alarm	Waits for power supply to be reset.
EE	Inverter monitor timer over (1 s elapsed)	Communications alarm	Waits for power supply to be reset. Received commands are ignored.*

* If the ERR indicator is not lit or flashing, any commands that are received will be ignored.

■ Inverter Fault Notification

If a fault is detected in the Inverter, the SI-T/V7 stores the alarm or warning code in the MECHATROLINK-II ALARM command and simultaneously turns ON the relevant bit in the STATUS field.

The following table shows the alarm codes for SI-T/V7 notification if a fault is detected in the Inverter.

Table 10 Inverter Alarm Codes

ALARM	Digital Operator Display	Description	Remarks
02H	UV1	Main circuit undervoltage	
03H	UV2	Control power supply undervoltage	
06H	GF	Ground fault	5.5/7.5 kW only
07H	OC	Overcurrent	
08H	OV	Overvoltage	
09H	OH	Inverter overheat	
0BH	OL1	Motor overload	
0CH	OL2	Inverter overload	
0DH	OL3	Overtorque 1	
10H	RH	Braking resistor overheat	5.5/7.5 kW only
11H	EF3	External fault 3	
12H	EF4	External fault 4	
13H	EF5	External fault 5	
14H	EF6	External fault 6	
15H	EF7	External fault 7	
1BH	PF	Input open phase	
1CH	LF	Output open phase	
1EH	OPR	Digital Operator connection fault	
21H	CE	MEMOBUS transmission fault	
E6H	BUS	Optional transmission fault	
E5H	E5	SI-T WDT fault	
27H	EF0	External fault	
29H	UL3	Undertorque detection 1	
50H	STP	Emergency stop	
51H	EF1	External fault 1	
52H	EF2	External fault 2	
84H	CPF04	EEPROM fault	
85H	CPF05	CPU internal A/D fault	
8CH	CPF07	Digital Operator control circuit fault	
93H	CPF22	Communications optional model code fault	
94H	CPF23	Communications optional mutual-diagnostic fault	

Table 11 Inverter Warning Codes

ALARM	Digital Operator Display	Description
01H	UV	Main circuit undervoltage
02H	OV	Overvoltage
03H	OH	Inverter overheat
05H	OL3	Overtorque 1
07H	EF	External fault
08H	BB	External baseblock
0FH	FAN	Cooling fan fault
13H	OPR	Digital Operator connection fault
14H	CE	MEMOBUS transmission fault
1CH	FBL	PID feedback reference loss
1DH	CALL	Waiting to receive data
1EH	UL3	Undertorque detection 1
20H	SEr	Sequence input fault
22H	OH3	Motor overheat 1
40H	STP	Emergency stop
41H	STP	Emergency stop

Table 12 Causes and Countermeasures of Main Faults Displayed on VSmini V7 Digital Operator

Display	Description	Cause	Countermeasures
BUS	Optional communications error	Communications are not established with the host controller.	Check the LED indicators. Check the communications cable wiring.
E5	SI-T WDT error	There is no continuity in the WDT for data sent by the host controller.	Execute DISCONNECT or ALM_CLR, and then use either the CONNECT or SYNC_SET command to move to phase 3.
EF0	External fault from option	An external fault is being input from the host controller.	Turn OFF the faulty input.
F06	Optional Connection fault	The Inverter and communications option are not properly connected.	Turn OFF the power to the Inverter and check the connection between the Option Unit and the Inverter. Then turn the power back ON. If the fault persists, replace the Option Unit.
F21	Communications optional self-diagnostic fault	The communications option is faulty.	Turn OFF and back ON the power to the Inverter. If the fault persists, replace the Option Unit.
F22	Communications optional model code fault		
F23	Communications optional mutual-diagnostic fault		

For information on the causes and countermeasures for other faults, refer to the *VS-606 V7 Series Instruction Manual* (Manual NO.: TOE-S606-11).

9 Specifications

Item	Requirements
Baud rate	4 Mbps or 10 Mbps ^{*1}
Access mode	Start-stop synchronization, master/slave method
Transmission cycle	500 μ s to 8 ms ^{*2}
Transmission distance	50 m max.
Data length	17-byte data transmission or 32-byte data transmission ^{*3}
Number of connectable stations	30 slaves max. ^{*4, *5}
Operating Power Supply	4.75 VDC to 5.25 VDC (supplied from Inverter)
Ambient Temperature	-10°C to 45°C
Humidity	95% max. (with no condensation)
Storage Temperature	-20°C to 60°C
Location	Indoors (free from corrosive gases or dust)
Elevation	1000 m max.

- * 1. The baud rate is 4 Mbps for MECHATROLINK-I, and 10 Mbps for MECHATROLINK-II.
- * 2. For MECHATROLINK-I, a cycle is 2 ms. For MECHATROLINK-II, a cycle is 1 ms to 8 ms for a 32-byte data transmission, and 500 μ s to 8 ms for a 17-byte data transmission.
- * 3. For MECHATROLINK-I, only a 17-byte data transmission can be selected.
- * 4. The maximum number of connectable stations changes depending on the types and settings of the host controller, baud rate, or communications cycle. For details, refer to the manuals of your controller.
 Communications cycle: Integral multiple of transmission cycles (depending on the host controller settings).
 Example: If the host controller is an MP2300
 - For MECHATROLINK-II (32-byte transmission, 2-ms communications cycle):
21 stations max. (21 slaves can be set, but then the maximum number of connectable Inverters will be 16.)
 - For MECHATROLINK-II (32-byte transmission, 1-ms communications cycle):
9 stations max.
 - For MECHATROLINK-II (17-byte transmission, 1-ms communications cycle):
15 stations max.
 - For MECHATROLINK-I: 14 stations max.
- * 5. At the maximum transmission distance of 50 m, the maximum number of slaves is 15.

Revision History

The revision dates and numbers of the revised manuals are given on the bottom of the back cover.

MANUAL NO. SIBP C730600 03A

© Printed in Japan January 2005 05-1

└ Date of
printing

└ Date of original
publication

Date of Printing	Rev. No.	Section	Revised Content
January 2005	—		First edition

VS mini V7 OPTION UNIT MECHATROLINK COMMUNICATIONS INTERFACE UNIT USER'S MANUAL

IRUMA BUSINESS CENTER

480, Kamifujisawa, Iruma, Saitama 358-8555, Japan
Phone 81-4-2962-5696 Fax 81-4-2962-6138

YASKAWA ELECTRIC AMERICA, INC.

2121 Norman Drive South, Waukegan, IL 60085, U.S.A.
Phone 1-847-887-7000 Fax 1-847-887-7370

MOTOMAN INC. HEADQUARTERS

805 Liberty Lane West Carrollton, OH 45449, U.S.A.
Phone 1-937-847-6200 Fax 1-937-847-6277

YASKAWA ELÉTRICO DO BRASIL COMÉRCIO LTD.A.

Avenida Fagundes Filho, 620 Bairro Saude-Sao Paulo-SP, Brazil CEP: 04304-000
Phone 55-11-5071-2552 Fax 55-11-5581-8795

YASKAWA ELECTRIC EUROPE GmbH

Am Kronberger Hang 2, 65824 Schwalbach, Germany
Phone 49-6196-569-300 Fax 49-6196-569-312

Motoman Robotics Europe AB

Box 504 S38525 Torsås, Sweden
Phone 46-486-48800 Fax 46-486-41410

Motoman Robotec GmbH

Kammerfeldstraße 1, 85391 Allershausen, Germany
Phone 49-8166-90-100 Fax 49-8166-90-103

YASKAWA ELECTRIC UK LTD.

1 Hunt Hill Orchardton Woods Cumbernauld, G68 9LF, United Kingdom
Phone 44-1236-735000 Fax 44-1236-458182

YASKAWA ELECTRIC KOREA CORPORATION

7F, Doore Bldg. 24, Yeoido-dong, Youngdungpo-Ku, Seoul 150-877, Korea
Phone 82-2-784-7844 Fax 82-2-784-8495

YASKAWA ELECTRIC (SINGAPORE) PTE. LTD.

151 Lorong Chuan, #04-01, New Tech Park Singapore 556741, Singapore
Phone 65-6282-3003 Fax 65-6289-3003

YASKAWA ELECTRIC (SHANGHAI) CO., LTD.

No.18 Xizang Zhong Road. Room 1805, Harbour Ring Plaza Shanghai 20000, China
Phone 86-21-5385-2200 Fax 86-21-5385-3299

YATEC ENGINEERING CORPORATION

4F., No.49 Wu Kong 6 Rd, Wu-Ku Industrial Park, Taipei, Taiwan
Phone 886-2-2298-3676 Fax 886-2-2298-3677

YASKAWA ELECTRIC (HK) COMPANY LIMITED

Rm. 2909-10, Hong Kong Plaza, 186-191 Connaught Road West, Hong Kong
Phone 852-2803-2385 Fax 852-2547-5773

BEIJING OFFICE

Room No. 301 Office Building of Beijing International Club, 21
Jianguomenwai Avenue, Beijing 100020, China
Phone 86-10-6532-1850 Fax 86-10-6532-1851

TAIPEI OFFICE

9F, 16, Nanking E. Rd., Sec. 3, Taipei, Taiwan
Phone 886-2-2502-5003 Fax 886-2-2505-1280

SHANGHAI YASKAWA-TONGJI M & E CO., LTD.

27 Hui He Road Shanghai China 200437
Phone 86-21-6553-6060 Fax 86-21-5588-1190

BEIJING YASKAWA BEIKE AUTOMATION ENGINEERING CO., LTD.

30 Xue Yuan Road, Haidian, Beijing P.R. China Post Code: 100083
Phone 86-10-6233-2782 Fax 86-10-6232-1536

SHOUGANG MOTOMAN ROBOT CO., LTD.

7, Yongchang-North Street, Beijing Economic Technological Investment & Development Area,
Beijing 100076, P.R. China
Phone 86-10-6788-0551 Fax 86-10-6788-2878



YASKAWA ELECTRIC CORPORATION

YASKAWA

In the event that the end user of this product is to be the military and said product is to be employed in any weapons systems or the manufacture thereof, the export will fall under the relevant regulations as stipulated in the Foreign Exchange and Foreign Trade Regulations. Therefore, be sure to follow all procedures and submit all relevant documentation according to any and all rules, regulations and laws that may apply.

Specifications are subject to change without notice for ongoing product modifications and improvements.

© 2005 YASKAWA ELECTRIC CORPORATION. All rights reserved.

MANUAL NO. SIBP C730600 03A

Printed in Japan January 2005 05-1

04-8⑥ 03-73029