

VARISPEED-616G5 OPTION CARD  
PG SPEED CONTROL CARD PG-D2  
**INSTRUCTIONS**

---

Upon receipt of the product and prior to initial operation, read these instructions thoroughly, and retain for future reference.

---



---

## NOTES FOR SAFE OPERATION

Read this instruction manual thoroughly before installation, operation, maintenance or inspection. In this manual, the NOTES FOR SAFE OPERATION is classified as “CAUTION”.



Indicates a potentially hazardous situation which, if not avoided, may result in minor or moderate injury to personnel and damage to equipment.

It may also be used to alert against unsafe practices.

Even items described in  may result in a vital accident in some situations. In either case, follow these important items.

 : These are steps to be taken to insure proper operation and to avoid malfunctions, etc.

### CAUTION

- The option card uses a C MOS IC chip. It may break if touched by bare fingers because of static electricity. Be careful when handling.
- When removing the option card from the inverter for transportation or storage, put the card into the anti-static package it was in when delivered.
- Never change wiring or connect or disconnect connectors while the power is ON.

Failure to observe this caution may injure you.

PG speed control card, PG-D2 is mounted on the control board of the inverter, and performs speed feedback using the pulse generator (PG) on the motor to correct speed fluctuations caused by slipping. The card is used for v/f control with PG.

This option card is applicable to the following inverter series:  
VS-616G5: Entire series

Name	Code No.	Functions
PG speed control card PG-D2	73600-A014X	<ul style="list-style-type: none"> <li>• Applicable to RS-422 output PG</li> <li>• Phase A pulse (single phase pulse) input for v/f control</li> <li>• PG frequency range : 50 to 300kHz</li> <li>• Pulse monitor output : RS-422 output</li> </ul>

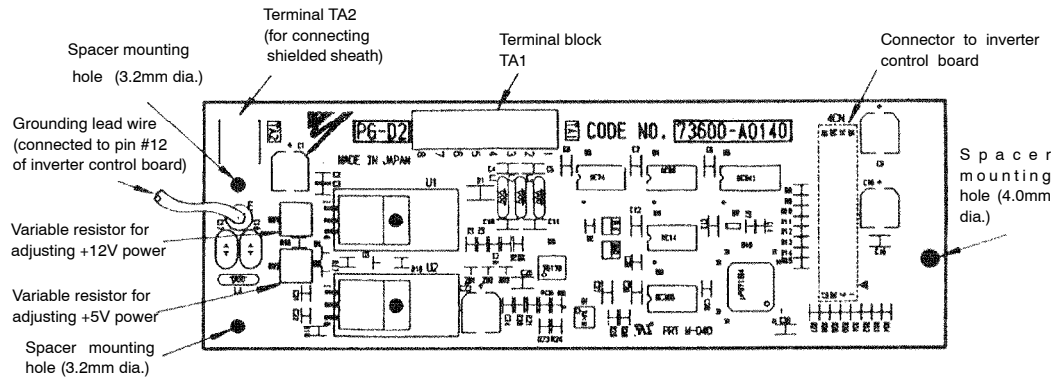

Fig. 1 PG speed control card PG-D2

Verify that the attachment below is in the package.

- Spacer : 1 pc. (Dimensions in mm)

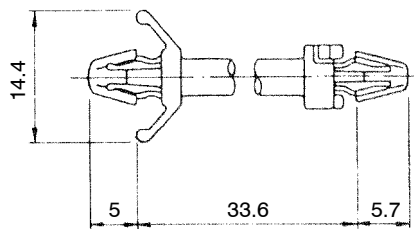

Fig. 2 Spacer (code no. SRNT41028-9)

 NOTE

Before use,

- (1) Before using PG-D2, read this manual and the manual for the installation of the inverter.
- (2) Before connecting PG-D2 or external terminals, turn OFF main power of the inverter and verify the CHARGE indicator lamp of the inverter is OFF.
- (3) When ordering PG-D2, specify the name and code number.

## 1 Inspection after Delivery



### CAUTION

- Verify that ordered products have been delivered.  
Installation of a wrong device may lead to injury or damage.

Though the products have undergone rigorous inspection before shipping, check the following for safety.

- Check the name written on the product to verify that ordered products have been delivered.
- Check for damage caused during transportation.

If there is anything uncertain on the structure, contact your YASKAWA representative.

## 2 Installing to Inverter (See Fig. 3)

### 2.1 Installation Procedure

- ① Turn OFF the main power and wait for the time specified on the cover of the inverter. Remove the cover and verify that the CHARGE indicator lamp is OFF.
- ② Insert the attached spacer (SRNT41028-9) into the spacer mounting hole in the mounting base of the inverter. (See Fig. 3.)

Inverters of 3.7kW or smaller capacities have two closely placed holes. Insert the spacer into the hole on the 7CN side. Inserting into the wrong hole will stack the spacer. Be careful to insert in the proper hole in the proper inserting direction.

- ③ Align the two holes of PG-D2 and projections as shown in the detailed side view, first at location (a) and then at (b), and precisely place the card on the option A connector. Insert the spacer mounted at ② above into the PG-D2 spacer mounting hole. (See part A of the side view.)  
Verify that 4CN is precisely aligned to PG-D2. Gently push the card until it clicks.

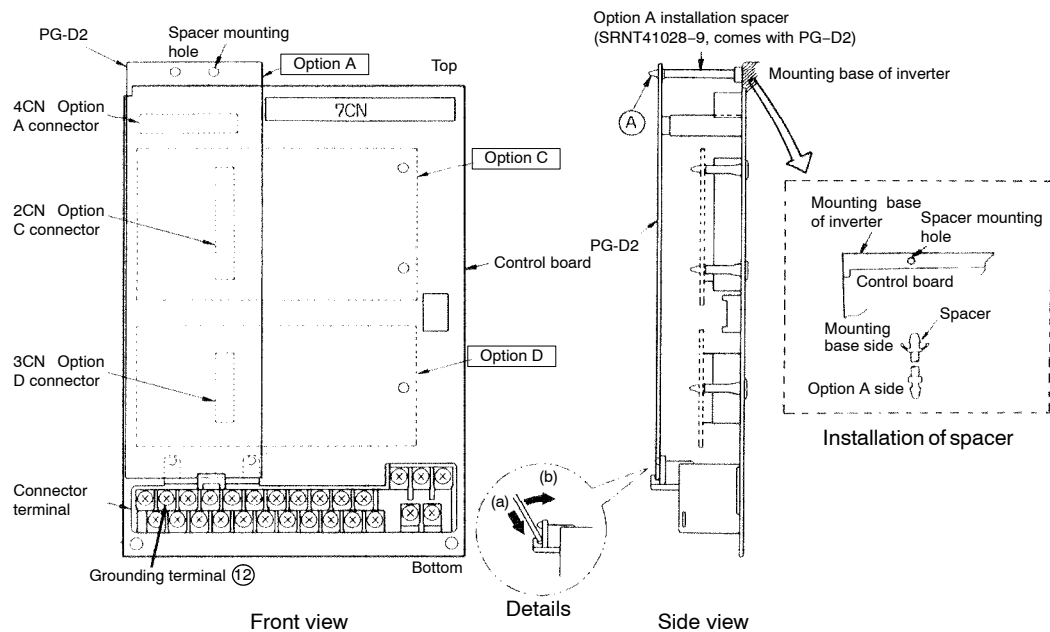

Fig. 3 Installation of PG speed control card PG-D2

### 3 Interconnection

Fig. 4 shows interconnection between the inverter, PG-D2, and peripheral equipment.

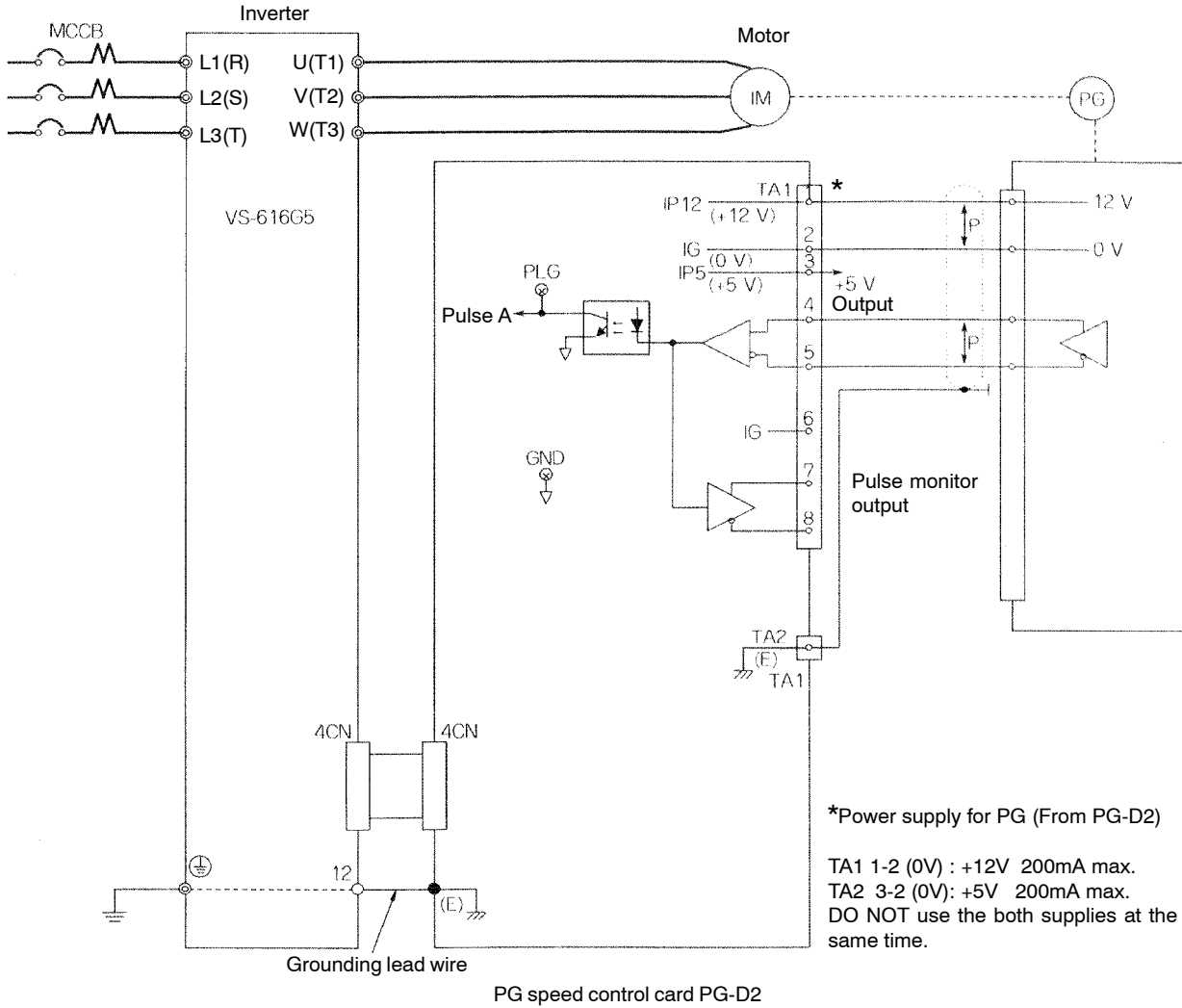

Fig. 4 Interconnection diagram



Notes on wiring

- Separate the control signal wire (from terminal TA1) of the PG-D2 from the main circuit wires and other power cables.
- Use a shielded wire to connect to the PG. Connect the wire as shown in Fig.5 to prevent interference by noise. The wire must be 50m or shorter.

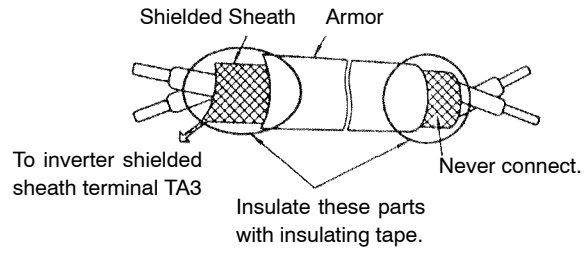

Fig. 5 Shielded wire termination

## 4 Wiring

See Table 1 for the functions of the external terminals.

Table 1 External terminals

Terminal block symbol	Pin No.		Functions
TA1	1	+12V	For power supply (+12V, +5V should not be used at the same time.) +12V 200mA max. +5V 200mA max.
	2	0V	
	3	+5V	
	4	+	PG signal input RS-422 level input
	5	-	
	6	0V	Common terminal
	7	+	Pulse monitor output RS-422 level output
	8	-	
TA2	Shielded sheath connection terminal		



Make sure the followings when wiring.

- To prevent noise, use shielded wire and separate from heavy current circuits (200VAC or greater) or relay drive circuits. (Wire length to the PG connector must be 50m or shorter.)
- Connect both ends of the unused wire of the shielded wire to the 0V terminal.
- Connect the grounding lead wire (E) to pin ⑫ of the control board of the inverter.
- Applicable wire sizes for terminal block TA1 is shown below.  
[Terminal: MKDS1 series manufactured by Phoenix Contact GmbH & Co.]

	[mm <sup>2</sup> ]	AWG	I [A]	VAC [V]
Thin twisted wire	1	16	12	125
Solid wire	1.5	16	12	125
UL	—	22-16	10	300
CSA	—	28-16	10	300
CSA	—	28-16	10	150



Terminal block TA1 side  
Connecting wire end

NOTE

#### Notes on selecting cables

Too thick a cable applies pressure to the option card and may lead to failure.

Too thin a cable may lead to imperfect contact or a break in the wire.

## 5 Selecting PG

The maximum frequency of PG output pulse that can be detected is 300kHz.  
Find output frequency,  $f_{PG}$  (Hz), according to the following formula.

$$f_{PG} \text{ (Hz)} = \frac{\text{Motor rotation speed (r/min) at max. frequency output}}{60} \times \text{PG constant (p/rev)}$$

If the PG power capacity is 200mA or greater, provide a separate power supply.  
(If momentary power loss ride-through function is necessary, provide backup capacitor or take other necessary measures.)

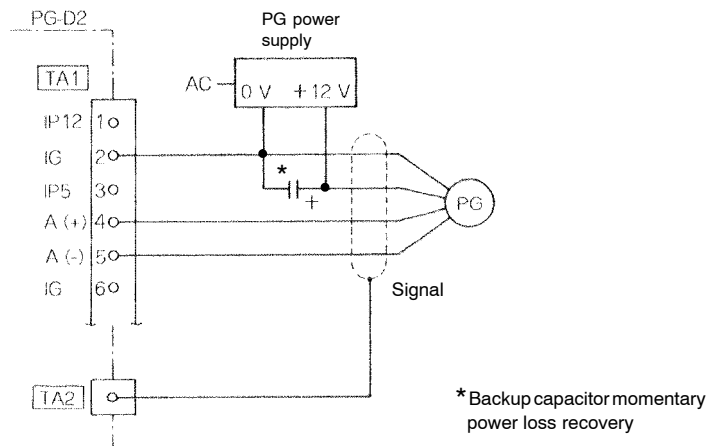

Fig. 6 Connection example with PG when using separate power supply

Table 2 Constants List

Digital Operator Function Display	Digital Operator Display	Constant No.	Constant Name	Setting Range	Factory Setting	Change during Operation (○=Enable, x=Disable)	Data Selection	Control Method (○=Setting enable, x=Setting disable)			
								V/f Control	V/f with PG Feedback	Open Loop Vector	Flux Vector
PG Option Setup	PG Pulse/Rev	F1-01	PG constant	0 to 60000	600	x		x	○	x	○
	PG Fdbk Loss Sel	F1-02	Operation selection at PG open circuit	0 to 3	1	x	0 : Ramp to Stop 1 : Coast to Stop 2 : Fast-Stop 3 : Alarm Only	x	○	x	○
	PG Overspeed Sel	F1-03	Operation selection at overspeed	0 to 3	1	x	0 : Ramp to Stop 1 : Coast to Stop 2 : Fast-Stop 3 : Alarm Only	x	○	x	○
	PG Deviation Sel	F1-04	Operation selection at deviation	0 to 3	1	x	0 : Ramp to Stop 1 : Coast to Stop 2 : Fast-Stop 3 : Alarm Only	x	○	x	○
	PG Rotation Sel	F1-05	PG rotation	0/1	0	x	0 : Fwd=C.C.W. 1 : Fwd=C.W.	x	○	x	○
	PG Output Ratio	F1-06	PG division rate	1 to 132	1	x		x	○	x	○
	PG Ramp P/I Sel	F1-07	Integral value during accel/decel enable/disable	0/1	0	x	0 : Disabled 1 : Enabled	x	○	x	x
	PG Overspd Level	F1-08	PG overspeed detection level	0 to 120%	115%	x		x	○	x	○
	PG Overspd Time	F1-09	PG overspeed detection delay time	0 to 2.0s	1.0s	x		x	○	x	○
	PG Deviate Level	F1-10	Excessive speed deviation detection level	0 to 50%	10%	x		x	○	x	○
	PG Deviate Time	F1-11	Excessive speed deviation detection delay time	0 to 2.0s	1.0s	x		x	○	x	○
ASR Tuning*	PG# Gear Teeth 1	F1-12	Number of PG gear teeth 1	0 to 1000	0	x		x	○	x	x
	PG# Gear Teeth 2	F1-13	Number of PG gear teeth 2	0 to 1000	0	x		x	○	x	x
	ASR P Gain 1	C5-01	ASR proportional gain 1	0 to 300.00	0.00	○		x	○	x	○
	ASR I Time 1	C5-02	ASR integral time 1	0 to 10.000sec	0.00sec	○		x	○	x	○
	ASR P Gain 2	C5-03	ASR proportional gain 2	0 to 300.00	0.00	○		x	○	x	○
	ASR I Time 2	C5-04	ASR integral time 2	0 to 10.000sec	0.00sec	○		x	○	x	○
	ASR Limit	C5-05	ASR limit	0.0 to 20.0%	0.0%	x		x	○	x	x
	ASR Delay Time	C5-06	ASR primary delay time	0.000 to 0.500s	0.000s	x		x	x	x	○
	ASR Gain SW Freq	C5-07	ASR switching frequency	0.0 to 400.0Hz	0.0Hz	x		x	x	x	○

\* ASR = Automatic Speed Regulation

# PG SPEED CONTROL CARD PG-D2 INSTRUCTIONS

**IRUMA BUSINESS CENTER**

480, Kamifujisawa, Iruma, Saitama 358-8555, Japan  
Phone 81-42-962-5696 Fax 81-42-962-6138

**YASKAWA ELECTRIC AMERICA, INC.**

2121 Norman Drive South, Waukegan, IL 60085, U.S.A.  
Phone 1-847-887-7000 Fax 1-847-887-7370

**MOTOMAN INC. HEADQUARTERS**

805 Liberty Lane West Carrollton, OH 45449, U.S.A.  
Phone 1-937-847-6200 Fax 1-937-847-6277

**YASKAWA ELÉTRICO DO BRASIL COMÉRCIO LTD.A.**

Avenida Fagundes Filho, 620 Bairro Saude-Sao Paulo-SP, Brazil CEP: 04304-000  
Phone 55-11-5071-2552 Fax 55-11-5581-8795

**YASKAWA ELECTRIC EUROPE GmbH**

Am Kronberger Hang 2, 65824 Schwalbach, Germany  
Phone 49-6196-569-300 Fax 49-6196-569-398

**Motoman Robotics Europe AB**

Box 504 S38525 Torsås, Sweden  
Phone 46-486-48800 Fax 46-486-41410

**Motoman Robotec GmbH**

Kammerfeldstraße 1, 85391 Allershausen, Germany  
Phone 49-8166-90-100 Fax 49-8166-90-103

**YASKAWA ELECTRIC UK LTD.**

1 Hunt Hill Orchardton Woods Cumbernauld, G68 9LF, United Kingdom  
Phone 44-1236-735000 Fax 44-1236-458182

**YASKAWA ELECTRIC KOREA CORPORATION**

Kipa Bldg #1201, 35-4 Youido-dong, Yeongdongpo-Ku, Seoul 150-010, Korea  
Phone 82-2-784-7844 Fax 82-2-784-8495

**YASKAWA ELECTRIC (SINGAPORE) PTE. LTD.**

151 Lorong Chuan, #04-01, New Tech Park Singapore 556741, Singapore  
Phone 65-6282-3003 Fax 65-6289-3003

**YASKAWA ELECTRIC (SHANGHAI) CO., LTD.**

4F, No.18 Aona Road, Waigaoqiao Free Trade Zone, Pudong New Area, Shanghai 200131, China  
Phone 86-21-5866-3470 Fax 86-21-5866-3869

**YATEC ENGINEERING CORPORATION**

4F., No.49 Wu Kong 6 Rd, Wu-Ku Industrial Park, Taipei, Taiwan  
Phone 886-2-2298-3676 Fax 886-2-2298-3677

**YASKAWA ELECTRIC (HK) COMPANY LIMITED**

Rm. 2909-10, Hong Kong Plaza, 186-191 Connaught Road West, Hong Kong  
Phone 852-2803-2385 Fax 852-2547-5773

**BEIJING OFFICE**

Room No. 301 Office Building of Beijing International Club, 21  
Jianguomenwai Avenue, Beijing 100020, China  
Phone 86-10-6532-1850 Fax 86-10-6532-1851

**TAIPEI OFFICE**

9F, 16, Nanking E. Rd., Sec. 3, Taipei, Taiwan  
Phone 886-2-2502-5003 Fax 886-2-2505-1280

**SHANGHAI YASKAWA-TONGJI M & E CO., LTD.**

27 Hui He Road Shanghai China 200437  
Phone 86-21-6553-6060 Fax 86-21-5588-1190

**BEIJING YASKAWA BEIKE AUTOMATION ENGINEERING CO., LTD.**

30 Xue Yuan Road, Haidian, Beijing P.R. China Post Code: 100083  
Phone 86-10-6233-2782 Fax 86-10-6232-1536

**SHOUGANG MOTOMAN ROBOT CO., LTD.**

7, Yongchang-North Street, Beijing Economic Technological Investment & Development Area,  
Beijing 100076, P.R. China  
Phone 86-10-6788-0551 Fax 86-10-6788-2878



YASKAWA ELECTRIC CORPORATION

YASKAWA

In the event that the end user of this product is to be the military and said product is to be employed in any weapons systems or the manufacture thereof, the export will fall under the relevant regulations as stipulated in the Foreign Exchange and Foreign Trade Regulations. Therefore, be sure to follow all procedures and submit all relevant documentation according to any and all rules, regulations and laws that may apply. Specifications are subject to change without notice for ongoing product modifications and improvements.

© 1995-2003 YASKAWA ELECTRIC CORPORATION. All rights reserved.

MANUAL NO. TOE-C736-40.3

© Printed in Japan February 2003 95-12 ◀  
02-11②